



©2013 The Early American Industries Association.  
May not be reprinted without permission.  
www.earlyamericanindustries.org

# The Chronicle

of the Early American Industries Association, Inc.  
Vol. 59, No. 2

June 2006

## The Early American Industries Association

*President:*  
Donald D. Rosebrook  
*Executive Director:*  
Elton W. Hall

THE PURPOSE of the Association is to encourage the study of and better understanding of early American industries in the home, in the shop, on the farm, and on the sea; also to discover, identify, classify, preserve and exhibit obsolete tools, implements and mechanical devices which were used in early America.

MEMBERSHIP in the EAIA is open to any person or organization sharing its interests and purposes. For membership information, write to Elton W. Hall, Executive

Director, 167 Bakerville Road, South Dartmouth, MA 02748 or e-mail: eaia@comcast.net.

## The Chronicle

*Editor:* Patty MacLeish

### *Editorial Board*

Katherine Boardman  
John Carter  
Jay Gaynor  
Raymond V. Giordano  
Rabbit Goody  
Charles F. Hummel  
Walter Jacob  
Johanna M. Lewis, Ph.D.  
Michael H. Lewis  
Dan Reibel  
Bill Robertson  
Jack Whelan  
Frank White

*The Chronicle* welcomes contributions from anyone interested in our purpose. Submit articles to: Patty MacLeish, Editor, 31 Walnut Street, Newport, RI 02840. Telephone: (401) 846-7542; Fax: (401) 846-6675; E-mail: pmaclish@verizon.net. We prefer articles to be submitted on disk or electronically. Please submit in any commonly used word processing program. If typed, please double space.

## Contents

### Tools and Machinery of the Granite Industry

by *Paul Wood* ----- 37

### Machines for Making Bricks in America, 1800-1850

by *Michael Pulice*----- 53

### American Bucksaws

by *Graham Stubbs* ----- 59

## Departments

### Stanley Tools by Walter W. Jacob

*The Advertising Signs of the Stanley Rule & Level Co.—*

*Script Logo Period (1910-1920)*----- 70

### Book Review: *Windsor-Chair Making in America, From Craft Shop to Consumer* by Nancy Goyne Evans

*Reviewed by Elton W. Hall* ----- 75

### Plane Chatter by J. M. Whelan

*An Unusual Iron Mounting* ----- 76

## Covers

**Front:** A bucksaw, patented in 1859 by James Haynes, and a nineteenth century saw-buck. Photograph by Graham Stubbs, who discusses American bucksaws in this issue beginning on page 59.

**Back:** A Stanley 9-x-18-inch baked enamel tin sign, circa 1910, manufactured by the New York Metal Ceiling Company. The sign is L-shaped and bent on the left edge so it could be fastened to the hardware store wall. Below is a Stanely embossed poster board sign (actual size 7 x 12<sup>3/4</sup> inch), circa 1912. Walter Jacob discusses Stanley signs in his article beginning on page 71.

*The Chronicle* of the Early American Industries Association, Inc. (ISSN 0012-8147) is published quarterly by the Early American Industries Association, Inc. Elton W. Hall, Treasurer, 167 Bakerville Road, South Dartmouth, MA 02748. POSTMASTER: Send address changes to: *The Chronicle* of the Early American Industries Association, Inc. c/o Elton W. Hall, Treasurer, 167 Bakerville Road, South Dartmouth, MA 02748. USPO Publication Number 560-620. Periodical postage paid at New Bedford, MA, and at additional mailing offices. ©2006 The Early American Industries Association. *The Chronicle* is available on microfilm from: ProQuest, 300 Zeeb Road, Ann Arbor, MI 48106. Articles appearing *The Chronicle* are abstracted and indexed in *Historical Abstracts* and *America: History And Life*. Design: Patty MacLeish, Ideas into Print, 31 Walnut Street, Newport, RI 02840. Printed by Cayuga Press, 1650 Hanshaw Road, Ithaca, NY 14850.



# Tools and Machinery of the Granite Industry

by Paul Wood

## Introduction

This article, the first in a series of four on granite working, deals with granite as a material, an industry, and a product and begins the description of the granite quarrying process. The second article will complete the account of granite quarrying. The final two articles concern the process of finishing granite and will conclude with a discussion of power sources, toolmaking, patents, granite workers, labor unions, and safety and health issues. The four articles will appear in consecutive issues of *The Chronicle*.

## Granite Composition

Granite is a very common stone found world-wide. Granite has been commercially quarried in the United States, Canada, Scotland, Finland, Italy, Ukraine, India, China, and Africa. Granite is found throughout the United States and has been commercially exploited in every New England state (Figure 1). Granite is composed primarily of quartz and feldspar with smaller amounts of mica. Quartz contributes to granite's strength, hardness, and luster, and acts as a cement binding all the elements together. Feldspar, granite's principal ingredient, occurs in a number of forms, mostly sodium/aluminum/silicon-rich plagioclase and potassium-rich microcline. In addition to contributing to strength and hardness, feldspar primarily determines granite's color, resistance to discoloration and decay, and ability to receive a polish. Mica (mostly white muscovite and black biotite) is present in much smaller amounts. The relative amounts of white and black mica are an important factor in both the color and commercial value of the granite. If white mica predominates, the granite will be light-colored, and if the black predominates, the granite will be dark, often approaching black. If the white and black occur in roughly equal amounts, the granite will be speckled. Since mica does not polish well nor does it retain its luster, excessive amounts of mica decrease the commercial value of granite. As an example, granite of the Barre, Vermont, area contains 31.7 percent plagioclase feldspar, 26.4 percent microcline feldspar, 23.3 percent quartz, 6.4 percent muscovite mica, 4.5 percent biotite mica, 2.7 percent orthoclase, 2.1 percent chlorite, and 1.6 percent calcite.

Granite is an igneous rock, formed by high heat and pressure from molten rock called magma. Deep magma over time forced its way up through fissures and cracks toward the surface where it cooled into columns of granite called plutons. Over millions of years, erosion, especially glaciation, exposed the tops of the plutons. In Barre, Vermont, it is estimated that the pluton is ten miles deep—plenty of granite for the future. If the cooling



Figure 1. Distribution of granite and allied rocks in the United States. The three primary areas are the along the Appalachian Mountains on the east coast, Wisconsin and Minnesota in the Great Lakes region, and California, Colorado, Idaho, and Arizona west of the Rockies.

**ROYAL BLUE GRANITE**

is hard, fine-grained, clear and durable. It comes in good patterns and is easy working. It is dark blue in color and shows a splendid contrast between its light hammered and dark polished surfaces. It is an ideal stone for polishing, closing up perfectly and retaining its dark blue color indefinitely.

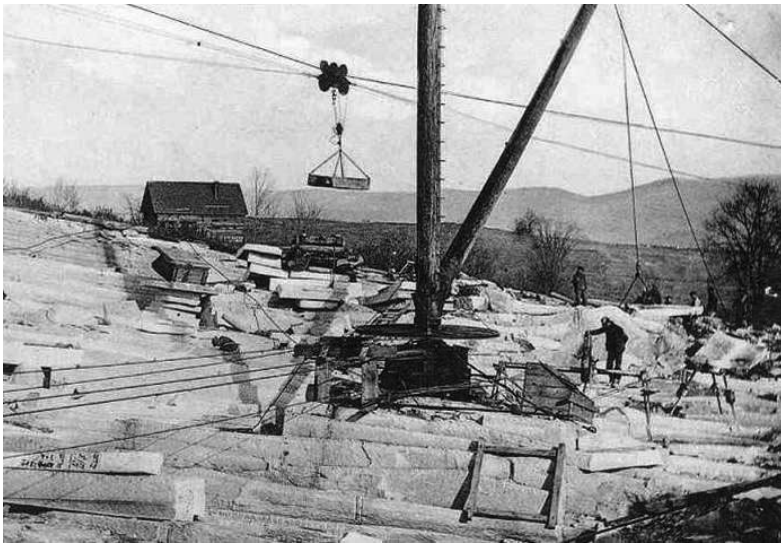
Send for free sample and prices of rough stock and slabs.

**CARTER GRANITE QUARRIES, INC.**  
Quarries, Hardwick, Vermont  
Office, Aldrich Building, Barre, Vermont

If you are interested in finished work from  
**ROYAL BLUE**  
send a trial order to us—now. Royal Blue, when polished, shows one of the best Blue and White surfaces in the granite industry. May we quote you on the above design?

**GEORGE Y. RALPH**  
Hardwick - Vermont  
"From the rough to a perfect ashler"

Figure 2. Carter's Royal Blue, a fine dark monumental granite from Hardwick, Vermont, shows a marked contrast between hammered and polished surfaces.



*Figure 3. The brightness of Bethel white granite is evident in this postcard view of the Woodbury Granite Co. quarry at Bethel, Vermont. From left to right can be seen a cableway with suspended grout box, guy boom derrick, quarry drill mounted on a channel bar, and a tripod drill mount.*

was slow, it produced coarse-grained, building-grade granite with large crystals, up to the size of a large pea. Monumental granite must be fine grained, with crystals the size of a pin head, to allow fine carved details and to accept a mirror-like polish. Fine monumental granite occurs, for example, at Barre, Vermont, Quincy, Massachusetts, and Westerly, Rhode Island, while building granite occurs at Woodbury and Bethel, Vermont. Only granite, certain marbles and a few dolomites can be polished. Limestone, soft marbles, and sandstones can be rubbed and honed but not polished. Monument designers exploit the marked contrast between dark-polished and light-hammered granite surfaces (Figure 2). Different quarries not only yield a range of grain sizes but also a wide variety of colors, including deep red, light pink, white, light gray, gray with blue tints, dark gray, and black. The white granite of Bethel, Vermont, is the whitest known granite, having almost the appearance of a fine white marble, and this white stone made the quarry so bright that many of the quarry workers wore dark glasses (Figure 3). Quarries also differ in the maximum size blocks that can be quarried without including a seam or defect. Most granite deposits are laminated by horizontal joints or cleavage. The distance between these joints typically increases with



*Figure 4. Cape chisel. The cape chisel is still used today by masons to remove old mortar in preparation for repointing.*

the depth of the quarry; hence, the deeper the quarry the larger the defect-free blocks that can be extracted.

Marble, limestone, and slate are granite's chief competitors. Marble is easy to rough out but difficult to finish. It carves beautifully and takes a sharp carved edge. However, marble does not stand up well out of doors since it dissolves, pits, and discolors in polluted air. Limestone is easy to work when freshly quarried, takes a sharp carved edge and weathers well outdoors. Slate is easy to work but due to its strong lines of cleavage is subject to flaking both while being worked and as it ages. Brownstone and sandstone were used for buildings in the nineteenth century, but these stones are very soft and subject to flaking and pitting. Granite is the hardest and most durable of the building and

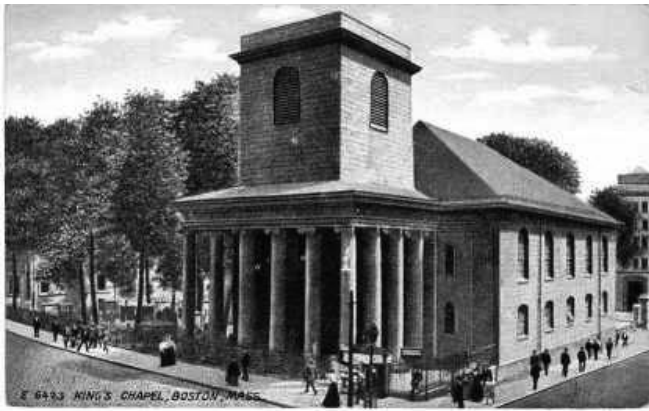
monumental stones and is the most difficult to quarry and to finish. The development of the granite business into a large-scale industry had to wait on the invention of more powerful and more efficient tools and machinery to deal with this obdurate stone.

## A Brief History of America's Granite Industry

Often farmers who lived where granite was found cut stone from boulders on the "back 40" as a part-time activity and used a corner of their barns as stone sheds. Some towns had common lands strewn with granite boulders. Boulders on the Braintree, Massachusetts, commons were the chief source of stone for local area building projects. People helped themselves until 1715, when the Braintree town fathers became concerned that the supply of stones would become exhausted, and they declared that from then on permission would be required to remove any stone.

The early stoneworker might have used any one of a number of historic splitting methods. This included heating by fire and then splitting by dousing with cold water, heating by fire and splitting by impact with an iron ball, heating by fire and splitting by impact with a large sledge, use of expanding ice in holes or cracks, use of expanding wet wooden wedges in cracks, and grooving and then hammering along the groove. The use of flat wedge and flat shims in holes made by a cape chisel (Figure 4) was a great improvement, providing better control over splitting. The invention of this





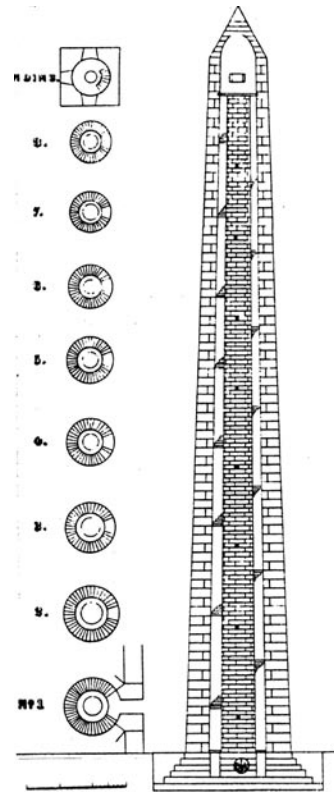
*Figure 5 (left). Kings Chapel, Boston, Massachusetts. Built from 1749 to 1754 of granite from the Braintree Commons, Kings Chapel was the largest granite structure attempted in the United States up to that time. The granite was to be “square pointed without pinners, the faces hammered square, and to be performed in every respect in a workman-like manner.”*

technique is attributed both to John Park of Scotland (circa 1770) and to Josiah Bemis, George Stearns, and Michael Wild of Groton, Massachusetts (circa 1803). At this time, granite was commonly used for retaining walls, house foundations, well linings, posts, steps, sills, lentils, hearthstones, wharves, and jetties. A few large granite structures were built in Boston in the eighteenth century including, Hancock House and King’s Chapel (Figure 5)—both of which were built of granite boulders from the Braintree commons—as well as the Old Powder House and the lighthouse on Beacon Island.

The granite industry in the United States first developed along coastal New England, where the quarries yielded different colored granite. In Maine, there was pink from Deer Island and light gray, almost white from Hallowell, and in Massachusetts blue gray or greenish from Cape Ann and dark gray in Quincy. Westerly, Rhode Island, granite, was gray and pink and Stony Brook, Connecticut, granite red.

Since granite is heavy and has a low value per pound, it was important that low-cost transportation be available. The sloops and schooners that plied New England’s coast filled this need. One early 1800s exception was the inland quarry at Chelmsford, Massachusetts. Barges on Middlesex Canal (built from 1795 to 1803) allowed the early development of the Chelmsford quarries (actually in Westford and Tyngsboro, Massachusetts) by making available low-cost shipment from Chelmsford to Boston’s Charles River. Some early nineteenth-century granite buildings erected in Boston, including some built from Chelmsford granite, were the Boston Courthouse, New South Church, Congregational House, Parkman House, and University Hall.

Solomon Willard is considered the father of commercial granite in the United States. He was a man of many talents—carpenter, carver in wood and stone, draftsman,



*Figure 6 (right). Sectional view of the Bunker Hill Monument. The design for the 295-step staircase is shown to the left, leading to an 11-foot by 11-foot by 17-foot high observation room. The monument required 6,700 tons of granite.*

architect, quarry operator, building contractor, and inventor of the central heating furnace and quarrying tools and machines. In 1825, Willard was chosen superintendent and architect for the Bunker Hill Monument (built from 1825 to 1843), a 220-foot high granite obelisk with a thirty-foot square base (Figure 6). For this pioneering granite structure, Willard searched throughout coastal New England for granite and concluded by purchasing a quarry in Quincy, Massachusetts, forever after known as the Bunker Hill Quarry. To facilitate the quarrying operation, Willard invented a boom derrick, lifting jack, pulling jack, and hoisting jack. These inventions, in addition to the early 1800s introduction of a new and better method of splitting using the plug drill and wedge and shims (described later in this article), put quarrying on a commercial footing. He was probably the first quarry operator to do detailed costing calculations and, much to the consternation of other quarry owners, quoted prices just barely above the quarrying cost.

Essential for the delivery of granite to the Bunker Hill Monument site was a railroad, designed by the master mason and engineer Gridley Bryant, that ran on a gradual downhill slope for a little over three miles from the quarry to a wharf on the Neponset River. From there, a schooner took the stone to the foot of Breed’s Hill. Bryant had designed a special car under which blocks of granite could be suspended and also a four-truck railway





Figure 7. *Boston Custom House (above). The construction of this Doric style building in the shape of a Greek cross was commenced in 1837. Thirty-two fluted columns, each weighing forty-two tons, surround the building. In 1915, a tower was added, using Cape Ann gray granite.*

Figure 8 (right). *The Wilbur Mausoleum in South Bethlehem, Pennsylvania, constructed from Woodbury, Vermont, gray granite.*



car with a capacity of sixty-four tons. The granite cars ran on iron-capped wooden rails with granite sleepers and could be pulled by a single horse. Bryant also designed a cable-operated inclined plane that transported the granite down a steep slope from the quarry to the beginning of the railroad. Other outstanding structures built from Bunker Hill Quarry granite were the Boston Custom House (completed in 1847) (Figure 7) and Minot's Ledge Lighthouse (completed in 1860).

Following the example set by Willard, New England quarry operators invented new ways of quarrying, shaping, handling, and transporting granite that resulted in much lower prices and in the availability of large blocks. The classical Greek revival style promoted by architects such as Charles Bullfinch, Alexander Parris, Solomon Willard, Ammi Burnham Young, and Gridley Bryant soon led to the design of many buildings utilizing the large granite blocks that had simplicity of design and resulted in a massive but clean effect. The 1870s through the 1890s was a period of active memorialization of the Civil War dead with large public memorials appearing in towns and cities across the nation. By 1900, architects were preoccupied with monumentality, volume, and formality. Great fortunes had been made by American businessmen and granite-faced, high-rise office buildings

were erected as monuments to their owner's business success. Large and elaborate granite mausoleums were purchased as memorials to themselves and their families (Figure 8). Granite mansions, the size of small hotels, were built in the fashionable sections of America's major cities. Indeed, granite had become a manifestation of conspicuous consumption.

As the railroads reached North America's interior, granite quarries were developed along the Appalachian Mountains, including Quebec, Canada (pink/rose); Woodbury, Vermont (gray); Barre, Vermont (gray); Bethel, Vermont (white); Concord, New Hampshire (blue-gray); Cooperstown, Pennsylvania (black); Mt. Airy, North Carolina (light gray); Salisbury, North Carolina (purplish pink); and Elberton, Georgia (blue). Also, a cluster of red granite quarries were developed in the Great Lakes region, including St. Cloud, Minnesota; Wassau, Wisconsin; Graniteville, Missouri; and Milbank, South Dakota. Rock of Ages Corporation, currently the nation's largest quarrier of granite, owns and operates nine quarries in the U.S., Canada and Ukraine and its quarries yield a variety of stone—Barre gray (Barre, Vermont), Bethel white (Bethel, Vermont), Salisbury pink (Salisbury, North Carolina), Gardenia white (Rockwell, North Carolina), American black (Morgantown, Pennsylvania), Kershaw pink (Kershaw, South Carolina), Coral gray (Kershaw, South Carolina), Laurentian pink (Guenette, Quebec), Stanstead gray (Stanstead, Quebec), and Galactic blue (Zhitomir, Ukraine).

## Granite Products

Granite has a remarkably wide range of uses, including monuments, buildings, skyscrapers, landscape products, precision products, and some unusual products not so easily categorized. By the late 1880s, granite monuments began to replace marble monuments that had earlier displaced slate monuments. Monuments include private gravestones and mausoleums, public memorials (mostly war memorials), and cemetery vaults. The market has changed for monuments. In the early part of the twentieth century, it was not uncommon for a significant portion of the deceased's estate to be spent on a memorial. The result was impressive monuments and mausoleums



on which skilled carvers and sculptors worked for weeks or months. Today, retailers, for the most part, emphasize low price, and few of the more impressive and more expensive monuments are sold. A four-foot wide monument with a five-foot wide base is now a rarity.

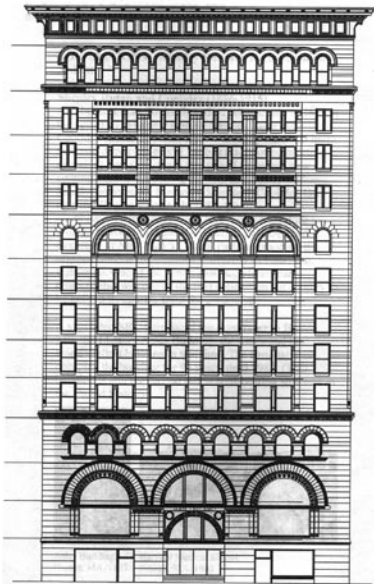
Granite facing was used for a wide variety of buildings, including federal, state, and local governments (federal buildings, state capitols, post offices, city halls,

court houses), businesses (banks, railroad stations, office buildings, department stores, hotels, theaters, garages), non-profit organizations (libraries, schools, museums, churches, hospitals), and private residences.

Of all the buildings, the skyscraper was the most dramatic. Initially, high-rise buildings were constructed using load bearing masonry walls in which the weight of the entire building was supported by the masonry wall. There are two historically important existing examples of buildings with load bearing walls. The Monadnock Building in Chicago was designed by Burnham & Root and built in 1889-91. The building has sixteen floors, the north half of which uses bearing wall construction—the tallest in the world. The building is supported by masonry walls, six-foot thick at the base. It was the last building designed by the noted architect John Wellborn Root. The other example is the Ames Building in Boston designed by Shepley, Rutan, & Coolidge and built in 1889 (Figure 9). It has thirteen floors and is the second tallest building with bearing wall construction. This building is supported by masonry walls, nine-feet thick at the base.

Since load bearing walls limited a building's height, a new design approach for high-rise buildings was invented using a steel framework with "curtain walls" of granite ashlar—four- to twelve-inch thick blocks with bed joints and end joints carefully and accurately cut so the blocks fit tightly together—supported at each floor by the steel frame. This new approach was pioneered in three Chicago buildings. The Home Insurance Building in Chicago, designed by William LaBaron Jenney, is ten stories high and was built in 1884-85. It was the first iron and steel frame building. It has iron columns, wrought iron and steel beams, and iron angle connecting brackets and a foundation consisting of stone and cement pyramid-shaped piers. The Rookery Building in Chicago, designed by Burnham & Root, has twelve stories and was built in 1886. It is the first building to use a steel-grillage foundation. The Tacoma Building in

*Figure 9 (left). The Ames Building, Boston, Massachusetts. This building served as the headquarters for the Ames Co., at one time America's largest manufacturer of shovels. The need for massive, thick bearing walls reduced both the usable floor area and the number and size of window openings (clearly apparent in the figure) for the prime rental space on the first and second floors.*



*Figure 10 (right). State Capitol, Madison, Wisconsin. Built in 1907 of white granite from Bethel, Vermont. At the time of its construction, it had the highest granite dome in the United States.*



*Figure 11 (below, left). State House, Harrisburg, Pennsylvania. Built in 1905 from Woodbury, Vermont, gray granite.*

*Figure 12 (below, right). Bankers Trust Co. Building, New York City. When built in 1910 with gray granite from Woodbury, Vermont, this building sat on the most expensive piece of real estate in New York City—a strong motivation to build high.*







Chicago, designed by Holibird & Roche, is fourteen stories high and was built in 1887. It was the first building to use curtain walls (in this case made of brick and terra-cotta) supported at each floor by the spandrel beams. A key motivation for the use of granite in skyscrapers was the pride of ownership of a building with a stone façade from sidewalk to the building's top. In the early twentieth century, the Woodbury Granite Co. of Hardwick, Vermont, using Woodbury, Vermont, granite, became the world's largest building granite company—supplying granite for, among other buildings, the impressive state capitols at Madison, Wisconsin (Figure 10), and in Harrisburg, Pennsylvania (Figure 11), the magnificent Pro Cathedral in Minneapolis, Minnesota, the Chicago City Hall and Cook County Courthouse, and the forty-six-story Bankers Trust Co. building in New York City (Figure 12).

Granite has been used for a variety of precision products including surface plates (a base for testing precision manufactured products), testing gauges, gauge blocks, press rolls (for the manufacture of newspaper), and chocolate rolls (for the milling of chocolate). Landscaping was another large granite market and included posts, steps, terrace paving, benches, stands, basins, birdbaths, fountains for gardens, curbstones for roads, and paving blocks for roads and sidewalks.

The utilization of grout (waste granite) was one of the most difficult problems for granite companies to solve—the large pieces of quarry grout could not be economically crushed and if used at all would only be appropriate for such uses as piers, breakwaters, rip rap, or fill. Currently, Swenson Granite Co. reports only 15 percent waste in its building granite quarrying operations at the Fletcher Quarry in Woodbury, Vermont. Rock of Ages Corp. reports that the E.L. Smith monumental quarry in Barre, Vermont, which has homogeneous defect-free

## Typical Workflow for the Extraction of a Quarry Saw Block (circa 1930s)

- CHALK MARKING** of deep and lift hole drill lines.
- DRILLING LINES** of deep holes along the sides and back of the quarry block.
- DRILLING LINES** of deep holes parallel to the front face of the quarry block.
- DRILLING A LINE** of lift holes along the bottom face of the quarry block.
- CHANNELING THE LINES** of side and back deep holes.
- LOADING THE LIFT HOLES** with black powder.
- BLOWING** the quarry block.
- SPLITTING OFF SMALLER BLOCKS** using black powder or wedges & shims in the deep holes parallel to the face of the quarry block.
- CHALK MARKING** of plug hole lines on the smaller blocks.
- DRILLING PLUG HOLES** in the smaller blocks.
- SPLITTING THE SMALLER BLOCKS** into saw blocks using wedges and shims in the plug holes.
- LIFTING OUT THE SAW BLOCKS** by boom derrick to the quarry edge.
- TRIMMING BLOCKS** to the size ordered by the sheds using a bull set and striking hammer.
- LOADING RAILROAD FLATCARS** by boom derrick for transport to the finishing sheds.

granite, is its highest recovery rate quarry with only 25 percent waste. Its other quarries have considerably higher percentages of waste. The Barre Granite Association (circa 1954) estimated an average of 75 percent waste for the Barre granite quarries. The higher percentage of waste, compared to building granite quarries, is due to the more discriminating selection of granite for monuments. Crushed granite—in sizes from a few inches to sand—for railroad ballast and road bases provided most of the market for grout. It is estimated that one mile of a two-lane highway requires forty thousand tons of aggregate, which consists of sand, gravel, and crushed

stone. Some other miscellaneous products made from waste granite included poultry grit (crushed, graded, and bagged), fertilizer (perhaps due to its potassium content), soil conditioner, additive for artificial stone, additive for bituminous concrete, and ship's ballast.

## Quarry Evolution

Quarry configurations have evolved along with the available quarrying technology. At first, fields of granite boulders, often glacial erratics scattered across a farmer's field, would be exploited for local consumption as house foundations, posts, hearths, and steps. Next, hillside quarries (Figure 13), consisting of exposed granite outcroppings on the sides of hills, would be exploited using small manual or horse-powered boom derricks. Also, sheet quarries of exposed horizontal sheets of granite crossed by wide-spaced steep joints might be developed, following the natural fault lines. For both hillside and sheet quarries, the granite was loaded by derrick onto ox- or horse-drawn wagons or sleds. In some quarries, boulder





*Figure 13 (left). Hillside quarry, Woodbury, Vermont, circa 1890s. Note the small dead-boom derrick and the horse, probably to power the derrick.*

*Figure 14 (below). Pit quarry, Barre, Vermont, circa 1950s. The large guy boom derrick has a “bull wheel” at the mast base to swing the boom. Note that one granite bench has a “keyway block” blasted out.*

quarries, the joints were so closely spaced that only small blocks “boulders” could be quarried. With the advent of large steam, compressed air or electric-powered derricks, it became possible to develop pit quarries (Figure 14) which extended quarrying hundreds of feet down into the granite plutons. Some pit quarries are as deep as five hundred feet with stepped-back quarry working faces. The stone is lifted out with derricks and loaded on railroad flatcars. Since the best stone is found at the lower layers of the quarry, the pit quarry allowed the extraction of large quantities of high-quality, defect-free granite. Finally, the use of the large-capacity, diesel-powered forklift truck led to the current development of drive-in quarries in which a vehicle can be driven directly to the quarry working face. Drive-in quarries can extract large amounts of granite with fewer quarrymen, the forklift trucks hauling the quarry blocks directly from the working faces and loading them on flatbed trucks.

### Removal of Overburden

The first task in the development of most quarries is the removal of the overburden or waste materials that usually cover at least a part of a proposed quarry site. These waste materials might include soil, boulders, and low-quality granite. Blasting with dynamite might be required to free some of the waste and to reduce it to manageable size. At first, removal was a manual operation assisted by ox or horse. An ox shovel would be used to drag waste to the edges of the quarry site. A manually loaded ox cart might be used to carry the waste greater distances. The waste removal operation reached a new level of efficiency with the introduction of the stripping cableway with



self-filling bucket (Figure 15). The cable extended across the quarry site and beyond. The scoop filled with waste as it was dragged across the surface and was automatically dumped at one side, out of the way of future quarry operations. Piling of grout on top of good granite was a costly lack of foresight. The cableway with skip, or grout box, was also used for the removal of overburden. The skip was filled with waste and automatically dumped onto waste piles at the quarry edge (Figure 16). Often, the cableway that was initially used for stripping was later used during

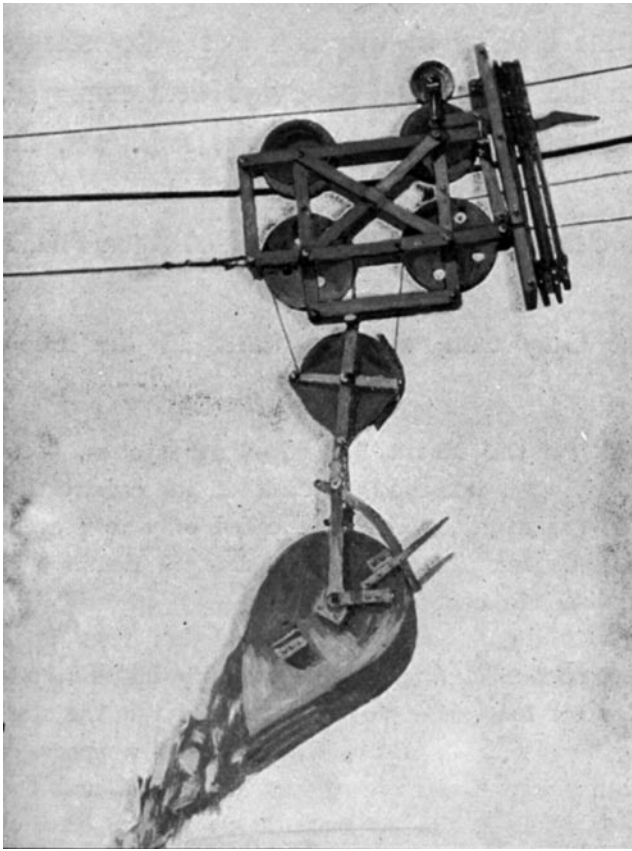


Figure 15. Cableway with self-filling bucket dumping its load.

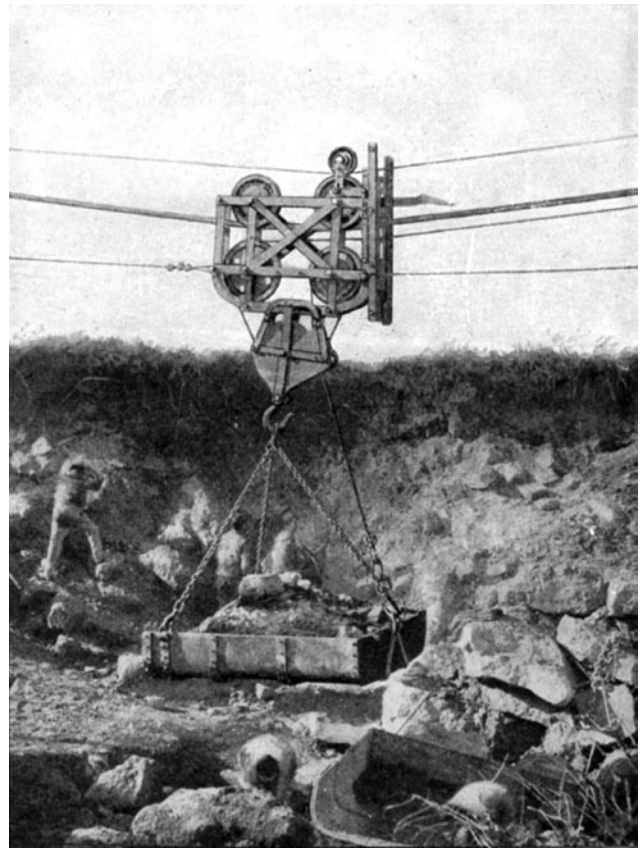


Figure 16. Cableway with grout box.

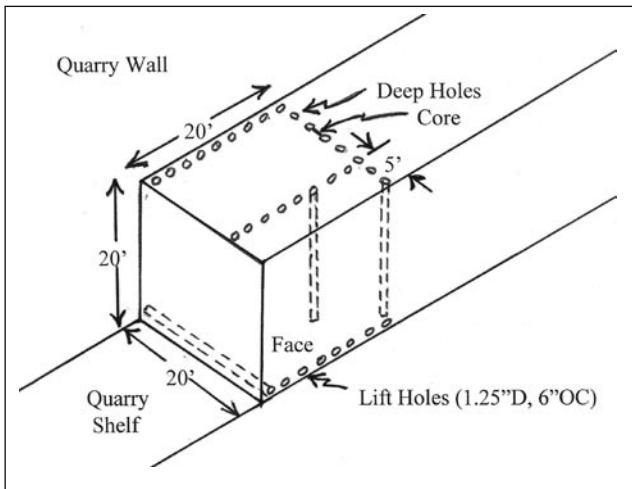


Figure 17 (above). Quarry drilling diagram showing deep and lift holes.

Figure 18 (below, left). Deep and lift hole hand drills.

Figure 19 (below, right). Drilling hammer.


Fig. 107.   
**OCTAGON OR QUARTER OCTAGON DEEP HOLE BLAST DRILL.**  
 Made from Best Crucible granite tool steel, all lengths in stock.  
 Fig. 107 Size steel  $\frac{3}{4}$  1 1 $\frac{1}{2}$  1 $\frac{3}{4}$  1 $\frac{1}{2}$  1 $\frac{1}{2}$  in. Price 10 cts. per lb.  
 Please state the size of hole you wish to drill also size of steel. Special low price on large lots.



Fig. 107A.   
**HAND CRUOIFORM Deep Hole Blast Drill.**

Fig. 107A are made from cruciform or corrugated Best Crucible Granite Tool Steel. These drills are made for seam work. Size steel  $\frac{1}{4}$   $\frac{1}{2}$  1 1 $\frac{1}{2}$  1 $\frac{3}{4}$  in. from 1 to 4 feet long 10 cts. per lb. Same size over 4 feet long cost 2c per lb extra. We fill in at the head and weld 6 to 8 inches in length so as to give a good striking surface.

quarrying operations for the removal of grout and small quarry blocks. Today, grout is usually not piled but rather backfilled on marginal land not likely to be used for future quarrying.

### Drilling Deep Holes and Lift Holes

Slate splits easily into sheets along cleavage planes. Marble and limestone can also be split relatively easily by the use of wedges. Granite is the hardest stone and the most difficult to split, but these two characteristics vary among the granites. For example, Barre, Vermont, granite is a harder stone and more difficult to split than Woodbury, Vermont, granite. Bethel, Vermont, granite drills harder and breaks harder than Barre granite. Even though granite is a much more difficult stone to split, it does have an easiest plane of splitting called the rift. Perpendicular to the rift is a



Made in weights from 3 to 4 1/2 lbs.  
 Price per lb. . . . . \$ .40





Figure 20. Double jacking deep holes.

Figure 21 (below). Deep hole and plug hole mud spoons.



plane of next easiest splitting called the lift or grain. Perpendicular to both these planes is a third plane of most difficult splitting called the hard way or head grain. Typically, the quarry block face (the front) and back are the hard way, the sides are the rift, and the top and bottom are the lift. Granite quarries are configured as a staircase of benches (the “steps”), each bench being typically twenty feet high and twenty feet deep and hundreds of feet in length. The first block extracted from the bench is called the keyway block (see Figure 14) and is often difficult to remove due to the sideways compressive forces that build up in granite deposits. After the keyway block is removed, the two adjacent blocks with three exposed surfaces are removed and so forth in both directions down the bench.

Two types of holes were drilled—vertical deep holes forming the sides and back of the quarry block to be extracted and horizontal lift holes forming the bottom of the block. These lines of holes were indicated with marking chalk, which was usually blue or red in half-globe cakes or square blocks, by the head quarryman. The holes were typically one and one-quarter inches in diameter, twenty feet deep, and spaced six inches on center. This resulted in a cube-shaped quarry block twenty feet on a side weighing about 680 tons (Figure 17). Initially, quarry drilling was a manual op-

eration using a hand drill and drilling hammer (Figures 18 and 19). For the deep holes, one quarryman held the drill and one (called single jacking) or two (double jacking) quarrymen swung the drilling hammers with the drill-holding quarryman rotating the drill slightly after each blow (Figure 20). It is believed that the terms single and double jacking came from “Cousin Jack,” a nickname for a Cornish miner. The drilling hammer had two beveled-edge striking faces and weighed three to four-and-a-half pounds. Hand drills came in graduated lengths and had either a star-shaped or flattened cutting head. Periodically, a deep hole mud spoon (Figure 21) was used to clean the powdered granite from the hole. For the lift holes, either a granite surface was available for the quarryman to stand on or scaffolding was erected on the face just below the intended line of drilled holes (Figure 22). The quarryman held and rotated the drill as well as swung the drilling hammer. In a Michigan hand drilling contest, a double jacking team drilled a fifty-nine-and-one-half-inch deep hole in Vermont granite in fifteen minutes. In a Colorado contest, a quarryman single-handedly drilled a twenty-six and five-eighths-inch deep hole in Colorado granite in fifteen minutes.

Steel granite-working hammers came in three basic varieties. Some hammers, like the drilling hammer, were designed to be swung and to strike steel granite-working tools of various kinds; other hammers were designed to be swung and to strike the granite directly, and finally, some hammers were designed to be held in place against the granite and to be struck by another hammer. In any situation where steel strikes steel, the hammer striking face is both tempered to provide impact resistance and beveled to reduce the chance of splintering. Granite workers are now required to wear

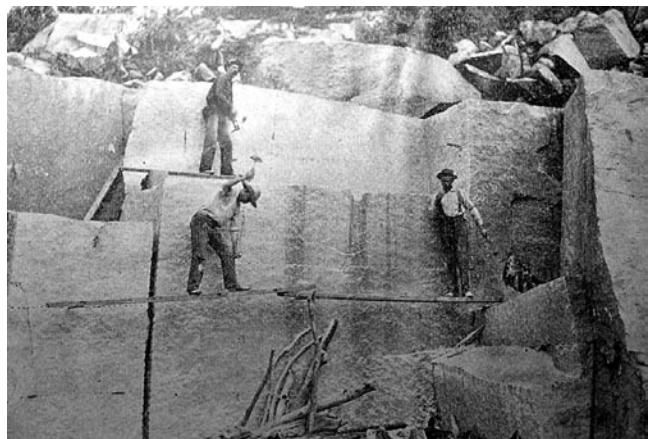
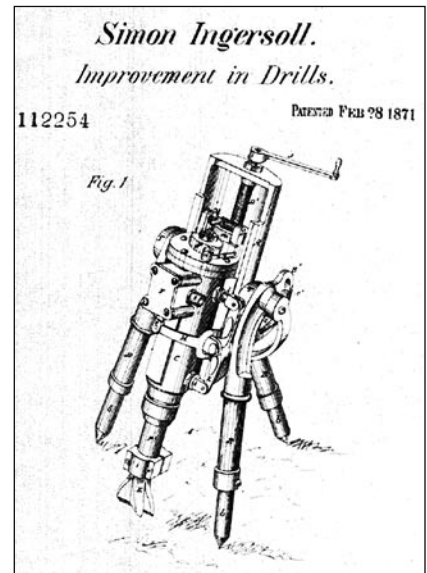
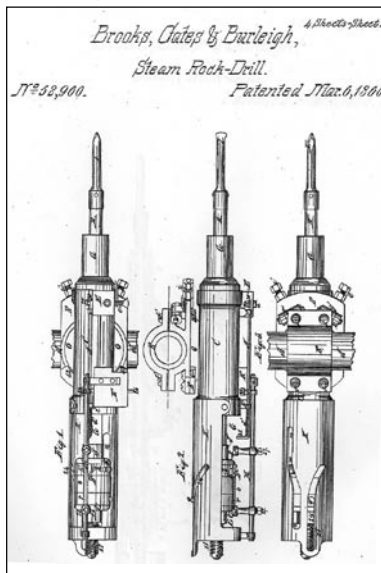
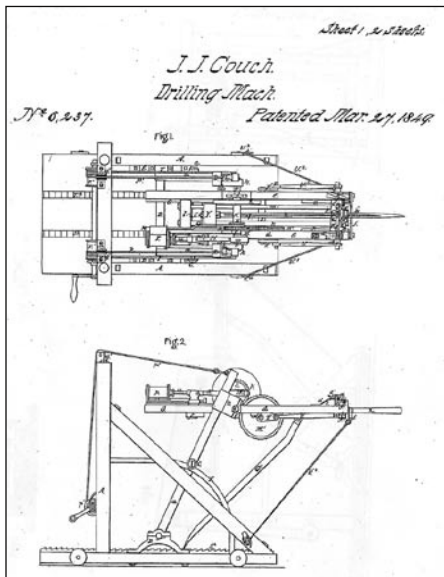


Figure 22. Hand drilling lift holes. Note the scaffolding supporting the quarrymen.





Figures 23, 24, and 25 (left to right). Three significant drill patents. Joseph Couch's 1849 steam rock drill patent; Charles Burleigh's 1866 steam rock drill patent; and Simon Ingersoll's 1871 steam rock drill patent.

protective glasses or goggles to prevent steel splinters from flying into their eyes. Repeated use causes striking faces to “swell” and thus need to be periodically ground back into their original shape. Hammer handles were usually made of hickory and were of various lengths, cross-sections, and shapes depending on the hammer size and use. Today, the buyer can order fiberglass handles as an option for most granite-working hammers.

Joseph Couch of North Bridgewater, Massachusetts, was issued the first patent for a steam-powered rock drill in 1849 (Figure 23). The patent describes a reciprocating percussion steam-powered rock drill. The drill, which weighed several thousand pounds, was mounted on a portable wheeled frame and could be adjusted to any angle from horizontal to vertical. Power was imparted to the drill bit from a steam cylinder by a gear and crank mechanism. A cam and wedge device grasped the drill bit during its forward motion and released it at its moment of impact with the stone. This was the first drilling mechanism that did not depend solely on gravity for the drilling stroke, and therefore, the first one that could be applied to other than vertical drilling. The drill bit was rotated after each impact. In 1852, Joseph Fowle of Boston, Massachusetts, was issued a patent for a less cumbersome version of the Couch drill. Fowle's design included the important innovation of the drill bit as an extension of the piston rod.

Charles Burleigh of Fitchburg, Massachusetts, and others were issued an 1866 patent for a number of improvements to the basic Couch/Fowle design—re-

sulting in the first practical and reliable steam drill (Figure 24). It was successfully used to drill the Hoosac Tunnel, the first mechanically bored American tunnel. Later, Burleigh bought the Fowle patent, which his drill infringed, and organized the Burleigh Rock Drill Co. In 1871, Simon Ingersoll of Brooklyn, New York, was issued patents for a feed rod/plunger/ratchet/wheel-nut combination that produced an automatic feed, for a supporting tripod drill stand with independently adjustable legs, and for a spiral bar to rotate the drill bit during operation (Figure 25). Henry Sergeant of New York City was issued an 1873 patent for a steam or pneumatic drill in which the drill bit was an extension of the piston rod. Sergeant claimed the improvements—rotating valves, cushioning piston stop, a new mechanism for revolving the drill bit, and automatic feed.

The widespread introduction (circa 1870s) of the steam quarry drills revolutionized the quarrying operation. Although steam drills were used up to the 1920s, pneumatic quarry drills began replacing steam drills by the early 1900s. The heart of the mechanical quarry drill is a mechanism called the valve, which directs the steam or compressed air alternately to the back and front of the drill piston. There were many valve designs, including unbalanced spool, tappet, auxiliary, butterfly, and ball and disc. Charles Burleigh had the first really successful drill that was manufactured in quantity. The Burleigh design had a piston with a slight hourglass-shaped curvature and piston rings at each end. It had a rod attached to the front of the piston that projected through a packing gland. The end of the rod was coke-bottle shaped



Cruciform steam drill bit made from corrugated Best Crucible Granite Tool Steel, all lengths to 25 feet. These drills are easier for the machine, clears better and are sharpened quicker.

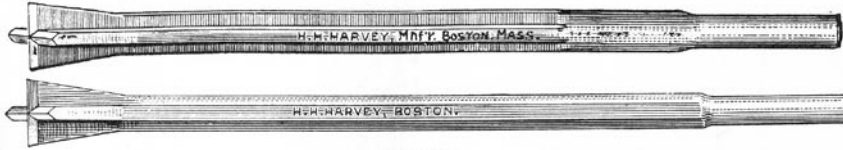


Fig. 1084.

Regular steam drill bit made from Octagon Best Crucible Granite Tool Steel.

Made in all the lengths to 35 feet or even longer if desired.

Sizes and Prices for Either Octagon or Cruciform Drill Bits for either Sargeant or Sigsbee Drills. See next page for the Rand and other drill bits.

(100 MUSEL)

J. G. LEYNER.  
 ROCK DRILL ENGINE.

No. 604,538.

Patented May 24, 1898.

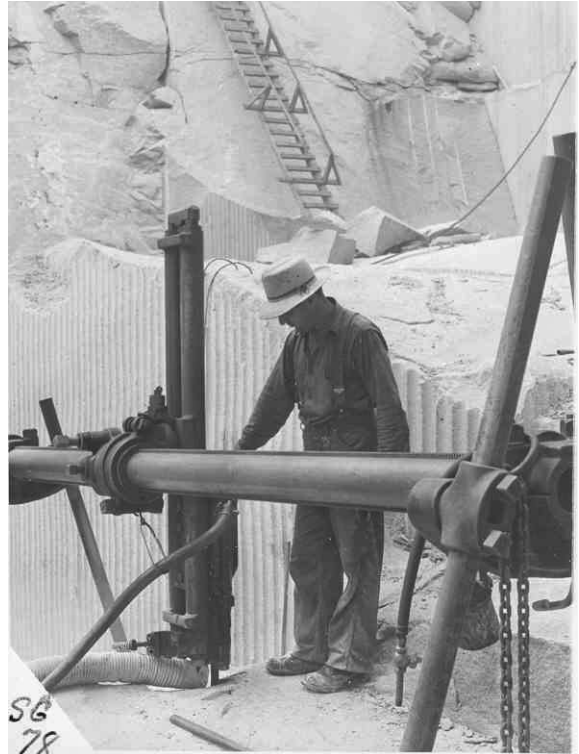
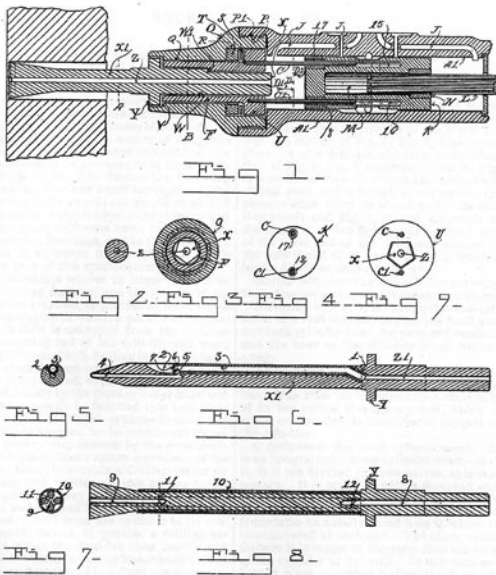


Figure 26 (left). Deep hole drill bits.

Figure 27 (below, left). John Leyner's 1898 hammer drill and hollow drill bit patent.

Figure 28 (below, right). Quarry drill mounted on a channel bar frame.

and bored out at the end to accept the drill bit (or drill steel) (Figure 26). A chuck with a U-bolt clamped the drill bit onto the piston rod. It also included a rifle bar device with a series of pawls to rotate the drill bit after each blow. This drill, in which the drill bit is connected directly to the piston, is called a piston-type drill and can achieve about six hundred blows per minute. Drill bits were sold in sets of increasing lengths. When the hole depth reached the length of the drill bit, the next longer drill bit was used. A drill bit set advertised for the Rand no. 5 steam drill consisted of a dozen octagonal shank, cruciform head drill bits in two-and-one-half-foot increments from two and one-half feet to thirty feet.

In 1898, John Leyner of Denver, Colorado, made two important improvements to the quarry drill, a drill bit that was no longer connected to the piston and a hollow drill bit to allow air or water to flush out the cuttings (Figure 27). The piston rotated with each blow and an attached chuck held and rotated the drill bit. Called a hammer-type drill, it could achieve

fifteen hundred blows per minute since it did not have to overcome the mass and friction of a long drill bit. With this drill, the bits could be easily removed and sent away for sharpening without taking the drill out of service. A blow tube, that carried air or water, ran through the center of the drill piston and its hammer head projection and into the hollow drill bit. Thus, the air or water was carried to the bottom of the drill hole where it flushed out the stone cuttings. Piston drills produced a pumping action of the drill bit that moved the cuttings out of the drill hole. Hammer drills could not do this since the drill bit did not move with the piston, and so cuttings would build up in the hole. Therefore, until sufficiently strong hollow drill bits could be manufactured, the hammer drill was primarily used for mine ceiling stopeing where the cuttings would fall out of the hole by gravity. Rock drills, which emit a thunderous roar and produce large quantities of airborne dust are, without protection, hazardous to human health. Today, quarry drillers normally wear



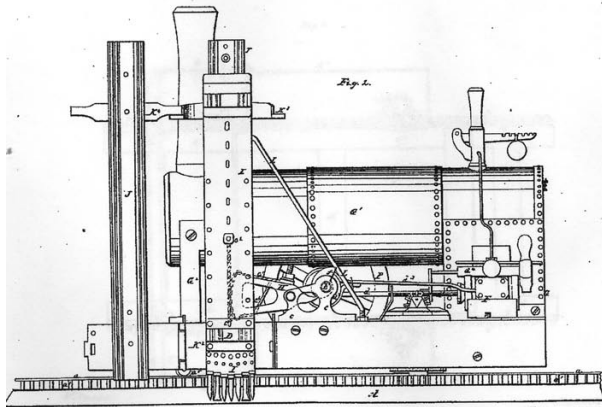
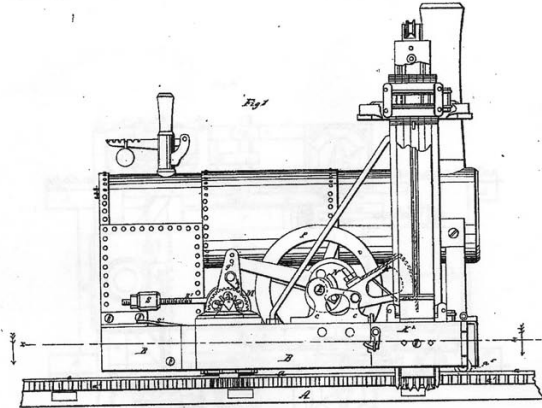
G. J. Wardwell.

3 Sheets, Sheet 1.

Stone-Channeling Machine.

No. 69,283.

Patented Sep. 24, 1867.



double ear protection. Wet drilling, made possible by Leyner's invention, greatly reduced the amount of airborne granite dust and saved the lives of thousands of quarrymen and miners. Before this time, mechanical quarry drills were called "widow makers" since many quarry workers succumbed to early deaths from silicosis induced tuberculosis.

Before the advent of carbide tips, drill bits had to be resharpened after about every two feet of drilling. Each drill operator had an assistant who mostly dealt with the drill bits. The drill bits were lifted and placed by the derrick, in front of the bench for the lift holes or on top of the bench for the deep holes. Some of the larger quarry operations used specialized drill-sharpening machines. The large drills used for lift and deep holes were mounted on a channel bar frame (Figure 28) or a tripod drill stand (see Figure 25). The channel bar frame was patented by Henry Sergeant of New York City in 1887. The frame was called a "channel bar" since it facilitated



Figure 29 (left). George Wardwell's 1867 stone channeling machine patent.

Figure 30 (above). Broaching bit (or channeling tool).

the drilling of a series of holes along a straight channel line. The bar was typically twenty feet long with two legs on each end. This design had a carriage that was driven along the bar by rack and pinion gearing and a circular journal that attached the drill to the carriage and allowed the drill to rotate to different angles—vertical for deep holes and horizontal for lift holes. The carriage location and the drill angle could each be changed without disturbing the other. This design was very popular and seen in many quarries. The most successful of the later pneumatic rock drills were valve-less. One of the all-time best drills, the Joy/Sullivan 360 drifter drill, was valve-less. It had a five- to six-inch diameter cylinder bore and is still manufactured. In the mid-1900s, using pneumatic drills, it took about two months of drilling to free a thirty-foot by thirty-foot by fifteen-foot-high quarry block. Currently, deep holes are drilled two inches in diameter and spaced three to four inches on center and the quarry blocks are typically thirty to forty feet long by forty feet wide by fifteen-feet high. A pneumatic, double, deep-hole rotary drill capable of drilling two holes simultaneously is used.

## Channeling

Channeling is the removal of all the granite along the side and back faces of the quarry block before the block is shot. In the 1860s, a carriage-mounted, steam-driven channeling machine with a linear array of chisels was developed for and successfully used on marble. It was briefly tried on granite but proved less effective for the much harder granite. George Wardwell of Rutland, Vermont (Figure 29), and Ebenezer Lamson of Windsor, Vermont, each applied for patents for channeling machines. Both were issued patents for channeling machines, and between the two, they held thirteen patents for the machine. The two men had an agreement to jointly produce a channeling machine, but Wardwell later backed out. Lamson then designed, patented, and built his own channeling machine. This situation led to a long, expensive, and acrimonious infringement lawsuit by Wardwell against Lamson, and the court eventually ruled that Lamson had infringed Wardwell's earlier patents.

For granite, the drilling of deep holes and chan-





neling by removal of the granite between the holes (called the core) proved much more effective. A quarry drill with broaching bit (or core cutter) (Figure 30) was used to break out the cores. The broaching bit had a four-inch-wide by one-inch-thick blade with a series of blunt teeth.

In the mid 1900s, the jet piercing (or torch cutting) technology was developed. It burned fuel oil and oxygen at a temperature of 4,000 degrees F, causing spalling (flaking off) of the granite due to the stresses set up by the differential heating of the granite. (This same spalling causes the destruction of granite exposed to the intense heat of building fires.) Jet piercing created the necessary twenty-foot-deep channels without the need of drilling deep holes. The burner was a complex tool, requiring water, electricity, compressed air, oil, and oxygen. The burner itself consisted of a long “pole” carrying fuel oil, pure oxygen, and cooling water. At the end of the pole was a copper tip where the oil and oxygen were mixed and burned. The initial design was manual, requiring two operators. Later, an automatic design was introduced requiring only a single operator.

In the late 1880s, M. Paulin Gay of Marseilles, France, designed and manufactured a wire saw that was used in quarries of France, Germany, Spain, Italy, and other European countries. The saw used three-strand twisted wire with a sand and water abrasive. The wire moved at a speed of sixteen feet per second and could cut about five hundred square feet of stone before wearing out. The wire was held in a pulley carrier and was forced down onto the stone by a screw feed mechanism. Two-and-a-half-foot diameter starter holes were required to accommodate the pulley carrier. Diamond-encrusted wire saws are now used for cutting the side faces. A one-and-one-quarter-inch diameter deep hole and lift hole joined at their bottoms are drilled for each side face. The saw wire is threaded through the holes, soldered into a loop, and driven by an electric motor mounted on a track. A set of gears moves the motor back an adjustable distance from the stone for every revolution of the wire. A diamond wire

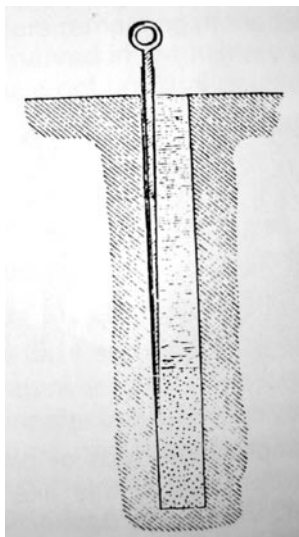


Figure 31. Sparkless pricker (or priming needle).

saw makes a very narrow cut—approximately one-half inch wide—and leaves spiral cut marks on the rock face. If a wire has to be replaced, it is a costly event since the wire costs approximately three dollars per foot.

Another currently used channeling technique employs a slot drill. First, two-and-one-half-inch diameter deep holes are drilled about four and one-half inches on center and then the cores are drilled out using a core drill with a three-inch diameter drill bit. A bit guide, inserted into an adjacent deep hole, is used to center the drill bit on the core. An experimental technology, water jet channeling, cuts channels at a rate of forty square feet per hour with high pressure (40,000 psi) water. This is a costly technology—a water jet power pack is valued at a hundred thousand dollars.

### Shooting (Blasting)

Black powder is used where less explosive force is desired, as is the case with quarrying dimension granite, which is used for building stones or monuments. Black powder consists of the granular ingredients sulphur, charcoal, which provides carbon to the reaction), and saltpetre (potassium nitrate), which provides oxygen to the reaction. It deflagrates at five hundred meters per second if contained and is termed a low explosive. Dynamite is a high explosive with a shattering and somewhat unpredictable effect and is often used to blast waste granite. Initially, loose black powder was loaded into the drilled holes and tamped in with a sparkless brass tamper. A sparkless pricker, also called a priming needle (Figure 31) was then used to make a hole in the compressed powder for insertion



Figure 32. Filling sand bags for shooting granite.



Figure 33. Blasting machine.

of a fuse. The fuse was typically a one-quarter-inch diameter cloth fiber wrapping a black powder core. Finally, loose sand was tamped into the hole to contain the blast and direct the blast forces perpendicular to the sides of the hole.

Later, black powder was manufactured in paper tubes (or sticks) that could be easily placed in the drilled holes. Some quarries “rolled their own” black powder in paper cartridges. Also, DuPont made cylindrical cakes of compressed black powder. For the first hole, a whole stick was placed in the back of the hole, a half stick in the middle, and a whole stick near the front. The next hole loaded was six or eight holes over and had a half stick in the back, a whole stick in the middle, and a half stick near the front. This process would be repeated until the end of the line of holes was reached. Sand in cylindrical bags was tamped in behind each stick (Figure 32). Today, electrically-fired primer cord explosive is loaded into every other lift hole.

Blasting caps were introduced as a much more reliable way to fire the charge. Blasting caps were initially non-electric with a fuse. Electrical detonation was a great improvement since it was safer and more holes could be shot at the same time. An electric blasting cap is fired by a blasting machine (Figure 33). There are a number of types of blasting machines, but all strive to produce every time a sufficient amplitude electric pulse. When there is an insufficient or marginal electrical pulse and blasting caps in series, the most sensitive caps detonate first and the remaining caps do not fire causing a misfire. The powderman must then deal with the remaining and dangerous unexploded powder—not



#### DEEP HOLE WEDGES AND SHIMS

Size	Size Wedge	Size Shim	Dia. of Hole	Approx. Wght. per set
6"	3/4"	3/4"	1 1/8"	1.6 lbs.
8"	1"	7/8"	1 1/4"	3 lbs.
12"	1"	7/8"	1 1/4"	4 1/2 lbs.
18"	1"	7/8"	1 1/4"	7 lbs.
24"	1"	7/8"	1 1/4"	9 1/2 lbs.
36"	1"	7/8"	1 1/4"	14 lbs.
48"	1"	7/8"	1 1/4"	19 lbs.
60"	1 1/8"	1"	1 3/8"	26 lbs.
72"	1 1/8"	1"	1 3/8"	32 lbs.
84"	1 1/4"	1"	1 1/2"	52 lbs.
96"	1 1/4"	1"	1 1/2"	60 lbs.

Figure 34. Deep hole wedges and shims.

knowing exactly where it is located. With the push-down plunger type blasting machine, the handle is pushed down as hard as possible—spinning a dynamo. When handle reaches the bottom, a switch made of a strip of brass under the handle is closed and an electric pulse is sent to the blasting caps. The pull-up plunger type works similarly, except that the handle is pulled up to spin the dynamo. The condenser discharge type blasting machine consistently produces a sufficient electrical pulse. A crank is turned to build up an electric charge on condensers and when a red light comes on the condensers are fully charged. The condensers can be discharged, by pushing a button, only after the red light comes on. Blasting caps can be wired in series, in parallel, or in series-parallel. For series-parallel wiring, the blasting caps are divided into groups in series with wires coming back to the blasting machine from each serial group. For example, there may be ten groups each with one hundred caps in series. Some blasting machines can handle up to a thousand blasting caps in series-parallel, which is an order of magnitude greater than was possible with non-electric blasting caps.

### Splitting Out Saw Blocks

At the same time the deep holes forming the back and sides of the block were drilled, three lines of vertical deep holes spaced about four inches apart were drilled along the hardway parallel to and at five-foot intervals back from the front face of the quarry block. These holes were used to blast or split off smaller twenty-foot by twenty-foot by five-foot blocks. After the powderman shot the quarry block, lifting and releasing it, he loaded



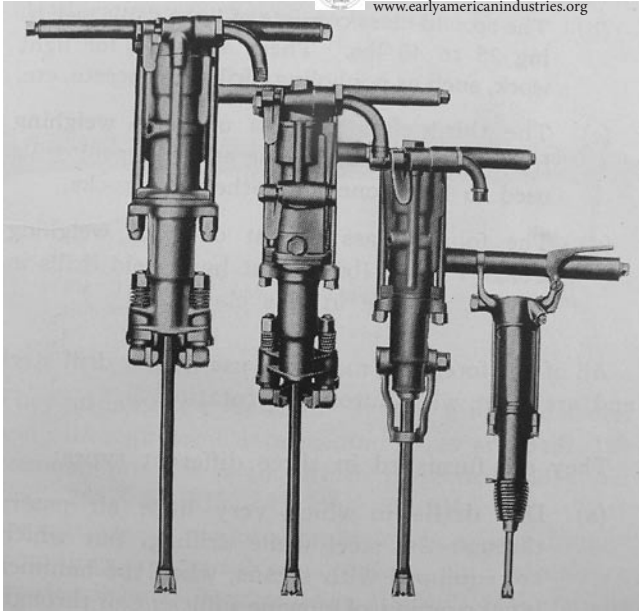


Figure 35. Jackhammers of various sizes.

and shot the first line of deep holes nearest and parallel to the front face. The explosion moved the smaller block forward and left a gap between it and the stone behind. If the stone was splitting easily, deep hole wedges and shims (Figure 34) could be used to split off these smaller blocks instead of the more expensive blasting. A pair of shims fit down either side of the hole with ears at the top to hold them in position at the top of the hole. Their outside surface was curved to fit the hole curvature and their inside surface was flat. A flat wedge was inserted between the shims and, as it was driven, slid along and pushed against the shims causing the shims to exert an outward force uniformly along their entire length against the sides of the hole. Deep hole wedges and shims could be up to ninety-six inches long and weigh sixty pounds per set. Splitters usually worked in two-man teams. One man drilled, and the other broke. The breaking quarryman tapped the wedges with a drilling hammer in sequence down the line of holes and then paused to let the stone



Figure 36. Driving the wedges.



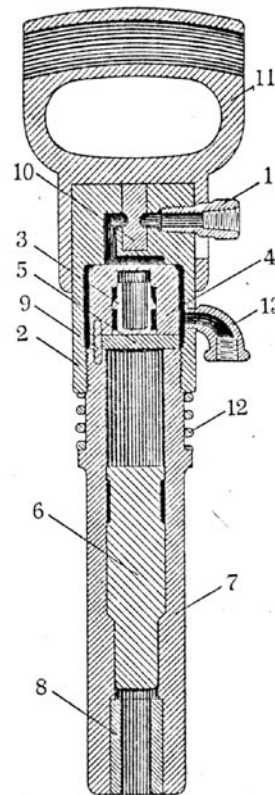
**HAND PLUG DRILL**  
 "Safe-Hed" Treated  
 Regular Length 17"

Size Stock	Bit End	Use With
3/4"	Dull	Wedges & Shims
3/4"	1/2"	No. 4, 5, 6 & 7
3/4"	7/16"	No. 2, 3 & 4

Figure 37. Hand plug drill.

work. Normally, three passes down the line were enough to split off the block. An alternative procedure might be employed using a jackhammer—a hand-held pneumatic hammer that can either drill or pound—(Figure 35) and short, heavy wedges known as steel glutts. When the first block was removed, the next line of deep holes was shot or split with wedges and so on.

Once a smaller twenty-foot by twenty-foot by five-foot block had been freed from the quarry block, it was



**PLUG DRILLER**

SIZE PDX		
Number of part		Name of part
1	.....	Nipple Bushing
2	.....	Cap
3	.....	Valve
4	.....	Valve Box
5	.....	Valve Box Plate
6	.....	Piston
7	.....	Cylinder
8	.....	Nose Bushing
9	.....	Dowel Pin
10	.....	Throttle Valve
11	.....	Handle
12	.....	Lock Spring
13	.....	Exhaust Elbow

Always give serial number of tool when ordering parts.

Figure 38 (above). Pneumatic plug drill (cross-section view).



Figure 39 (right). Plug drilling. Note wrench used to rotate the drill bit.



tipped over onto wooden beams or old tires, and was further reduced in size by splitting with wedges. Drill hole lines were drawn on one of the twenty-foot by twenty-foot faces with marking chalk by the head quarryman and typically yielded eight blocks, each five feet by five feet by ten feet, that were small enough (about twenty-one tons) to be removed by derrick or forklift truck. These were called saw blocks since they were just the right size to fit under a gang saw at the finishing shed. Lines of six-inch-deep, three-quarter-inch-diameter plug holes were drilled at three-inch intervals with a plug drill. Plug holes were just deep enough (about six inches) to accommodate the plug hole wedges and round shims. These wedges and shims, similar to but shorter than those used for deep holes, were sufficient since the splits were along the easy-splitting rift and lift planes and the stone was only five feet thick (Figure 36). Initially, plug holes were drilled manually using a hand plug drill (Figure 37) that was rotated after each blow by a drilling hammer. The plug drill has a flattened head with a blunt central point. Periodically, a plug hole mud spoon was used to clean the powdered granite from the hole. This is similar to but shorter than the mud spoon used for deep holes that has a socket for a long handle (see Figure 21). Later (circa 1902), the pneumatic plug drill (or sink drill) (Figure 38) was introduced. It was hand held and much smaller than the deep hole quarry drill, but at fourteen to twenty-five pounds, was larger than the stonecutter's pneumatic hammer (described in a later article). Some suppliers sold a small plug drill, called the "baby plugger," for shallow plug hole drilling. Drill rotation was done manually by a plug drill bit wrench that fit over the shank of the plug drill bit (Figure 39).

*The second article in this series, which will be published in September 2006, will complete the account of granite quarrying.*

## References

### Books and Journals

- Allen, Donald G. *Barre Granite Heritage with Guide to the Cemeteries*. The Friends of the Aldrich Public Library, 1997.
- Brayley, Arthur W. *History of the Granite Industry of New England*, vol. 1 and 2. The National Association of Granite Industries of the United States, 1913.
- Clarke, Rod. *Carved In Stone, A History of the Barre Granite Industry*. Rock of Ages Corp., 1989.
- Dale, T. Nelson. "The Granites of Vermont," *United States Geological Survey, Bulletin* 404, 1909.
- Dale, T. Nelson and Gregory, Herbert E. "The Granites of Connecticut," *United States Geological Survey, Bulletin* 484, 1911.
- Deborah Deford, ed. *Flesh and Stone, Stony Creek and the Age of Granite*. Stony Creek Granite Quarry Workers Celebration, 2000.

- Dickenson, E.H. "Rock Drill Data" *Compressed Air Magazine Co.*, 1960.
- Erkkila, Barbara H. *Hammers on Stone, The History of Cape Ann Granite*. Peter Smith, 1987.
- Gage, Mary and James. *The Art of Splitting Stone*, Powwow River Books, 2002.
- Garvin, Donna-Belle. "The Granite Quarries of Rattlesnake Hill," *Industrial Archeology* 20, no. 1-2, 1994.
- Granite Railway Company. *The First Railroad in America*, The Granite Railway Company, 1926.
- Hunt, Marjorie. *The Stone Carvers, Master Craftsmen of Washington National Cathedral*. Washington: Smithsonian Institution Press, 1999.
- John Fyfe Limited. *John Fyfe, One Hundred and Fifty Years, 1846-1996*. Time Pieces Publications, 1996 .
- Jones, Robert C. et al. *Vermont's Granite Railroads*. Boulder, Colo.: Pruett Publishing Co., 1985.
- King, Ross. *Brunelleschi's Dome*. New York: Walker & Co., 2000.
- Macomber, Stephen W. *The Story of Westerly Granite*. Westerly (Rhode Island) Historical Society, 1958.
- McKee, Harley J. *Introduction to Early American Masonry; Stone, Brick, Mortar and Plaster*. National Trust for Historical Preservation, 1973.
- McGarvey, G.A. and H.H. Sherman. *Granite Cutting, An Analysis of the Granite Cutter's Trade*, U.S. Department of the Interior, 1938 .
- Paton, Todd *The Rock of Ages Story*. Rock of Ages Corp., 2003.
- Poitras, Gregory B. *Stone Slabs and Iron Men, The Deer Isle Granite Industry*. Deer Island Granite Museum, 1997.
- Richardson, Eleanor M. *Hurricane Island—The Town that Disappeared*. Rockland, Maine: Island Institute, 1989.
- Rosner, David and Gerald Markowitz. *Deadly Dust, Silicosis and the Politics of Occupational Disease in Twentieth-Century America*. Princeton University Press, 1991.
- Sample, O.H. ed., *Monument Dealer's Manual*. Allied Arts Publishing Co., 1919.
- Starrett, W.A. *Skyscrapers*. Charles Scribner's Sons, 1928.
- Wheildon, William W. *Memoir of Solomon Willard*. Bunker Hill Monument Association, 1865.

### Catalogs

- H.H. Harvey, Pulsometer Steam Pump Co., Lincoln Iron Works, F.R. Patch Mfg. Co., Lidgerwood Mfg. Co., Thos. H. Dallett Co., Trow & Holden Co., Granite City Tool Co., Miles Supply Co., Bicknell Mfg. Co., Lima Locomotive & Machine Co.

### Periodicals

- Barre Life, Monumental News, Memorial Merchandising, Monument Builder News, Elberton Graniteer, American Art In Stone, The Memorial Builder, The American Architect*

## Author

EAIA member Paul Wood is a retired electrical engineer, who worked his entire career in the computer industry. He is interested in the tools, implements and machinery of the granite industry and of nineteenth- and early-twentieth-century farming in New England.





© 2006 The Early American Industries Association  
May not be reprinted without permission.  
www.earlyamericanindustries.org

# *The* CHRONICLE

of the  
Early American Industries Association



Tools and Machinery of the  
Granite Industry, Part II

Imprints and Characteristics  
of the Planes of Robert Wells, Elisha  
G. Wells, and Chester R. Wells

In Search of the Three-Lipped Auger  
The Three-Pod Auger

Corn Husking Pegs

A Henry Disston Full Back Mystery

Volume 59, Number 3

September 2006



The Early American  
Industries  
Association

*President:*  
Donald D. Rosebrook  
*Executive Director:*  
Elton W. Hall

THE PURPOSE of the Association is to encourage the study of and better understanding of early American industries in the home, in the shop, on the farm, and on the sea; also to discover, identify, classify, preserve and exhibit obsolete tools, implements and mechanical devices which were used in early America.

MEMBERSHIP in the EAIA is open to any person or organization sharing its interests and purposes. For membership information, write to Elton W. Hall, Executive Director, 167 Bakerville Road, South Dartmouth, MA 02748 or e-mail: eaia@comcast.net.

## The Chronicle

*Editor:* Patty MacLeish

### *Editorial Board*

Katherine Boardman  
John Carter  
Jay Gaynor  
Raymond V. Giordano  
Rabbit Goody  
Charles F. Hummel  
Walter Jacob  
Johanna M. Lewis, Ph.D.  
Michael H. Lewis  
Dan Reibel  
Bill Robertson  
Jack Whelan  
Frank White

*The Chronicle* welcomes contributions from anyone interested in our purpose. Submit articles to: Patty MacLeish, Editor, 31 Walnut Street, Newport, RI 02840. Telephone: (401) 846-7542; Fax: (401) 846-6675; E-mail: pmacleish@verizon.net. We prefer articles to be submitted on disk or electronically. Please submit in any commonly used word processing program. If typed, please double space.



©2013 The Early American Industries Association.  
May not be reprinted without permission.  
www.earlyamericanindustries.org

# The Chronicle

of the Early American Industries Association, Inc.  
Vol. 59, No. 3

September 2006

## Contents

Tools and Machinery of the Granite Industry, Part II <i>by Paul Wood</i> -----	81
Corn Husking Pegs <i>by Suzanne Fellman Jacob</i> -----	97
Imprints and Characteristics of the Planes of Robert Wells, Elisha G. Wells, and Chester R. Wells <i>by Patrick M. Kelly</i> -----	103
In Search of the Three-Lipped Auger <i>by Nick Nichols</i> -----	109
The Three-Pod Auger <i>by Bob Roger</i> -----	111
A Henry Disston Full Back Mystery <i>by Phil Baker</i> -----	113

## Departments

Stanley Tools by Walter W. Jacob <i>The History of Stanley Four-Square Household Tools Part 1</i> -----	114
Plane Chatter by J. M. Whelan <i>Facing Planes</i> -----	120

## Cover

**Front: Pit Quarry.** A recent photograph of the Rock of Ages E. L. Smith Quarry in Barre, Vermont. Note that all the wood derricks have been replaced by higher capacity steel derricks.

**Back: Quarrymen.** Granite quarry workers drilling a line of holes with jackhammers. Both photographs from the collection of Paul Wood.

*The Chronicle* of the Early American Industries Association, Inc. (ISSN 0012-8147) is published quarterly by the Early American Industries Association, Inc. Elton W. Hall, Treasurer, 167 Bakerville Road, South Dartmouth, MA 02748. POSTMASTER: Send address changes to: *The Chronicle* of the Early American Industries Association, Inc. c/o Elton W. Hall, Treasurer, 167 Bakerville Road, South Dartmouth, MA 02748. USPO Publication Number 560-620. Periodical postage paid at New Bedford, MA, and at additional mailing offices. ©2006 The Early American Industries Association. *The Chronicle* is available on microfilm from: ProQuest, 300 Zeeb Road, Ann Arbor, MI 48106. Articles appearing *The Chronicle* are abstracted and indexed in *Historical Abstracts* and *America: History And Life*. Design: Patty MacLeish, Ideas into Print, 31 Walnut Street, Newport, RI 02840. Printed by Cayuga Press, 1650 Hanshaw Road, Ithaca, NY 14850.





# Tools and Machinery of the Granite Industry, Part II

by Paul Wood

## Introduction

This article, the second in a series of four on granite working, completes the description of the quarrying process. The final two articles, dealing with granite finishing and other granite working topics, will appear in the next two issues of *The Chronicle*.

## Lifting and Moving

As long ago as the 1420s, Filippo Brunelleschi had invented an ox hoist with a five-foot diameter solid elm drum that lifted a total of seventy million pounds of marble, brick, stone, and mortar during the construction of the main dome on Florence's cathedral Santa Maria del Fiore (Figure 1). Brunelleschi also invented a balance crane that was similar to the modern tower crane with a long, horizontal, asymmetrical, counter-weighted boom. Four centuries later, Solomon Willard (circa 1820s) invented or perfected a boom derrick (called a "hoisting apparatus" in Figure 2), which in most respects the derrick used in today's granite quarries. He also invented or perfected other stone lifting

and moving devices, including the geared lifting jack, the screw hoisting jack, and the pulling jack (Figure 2). A fifteen-ton capacity double-geared lifting jack, very similar to Willard's jack, was still being made and sold for \$125 at the turn of the twentieth century (Figure 3). A modern counterpart of Willard's pulling jack is the "tugger," a small, one-drum, compressed-air hoist mounted on the front of a steel plate. The plate rests on the quarry floor and is secured in place by a wire rope fixed to two holes in the back corners of the plate and running around a two-inch steel anchor pin driven into the floor of the quarry. The operator stands on the back of the plate behind the hoist and controls the hoist by a lever that causes power to be applied to the drum and a second lever that brakes the drum. The tugger is most useful in areas that the boom derricks cannot reach.

During the latter part of the nineteenth century and most of the twentieth century, the boom derrick did the majority of the heavy lifting at the quarry and in the finishing shed yard. The "derrick sticks" (mast and boom) were made of Douglas fir, up to four feet in

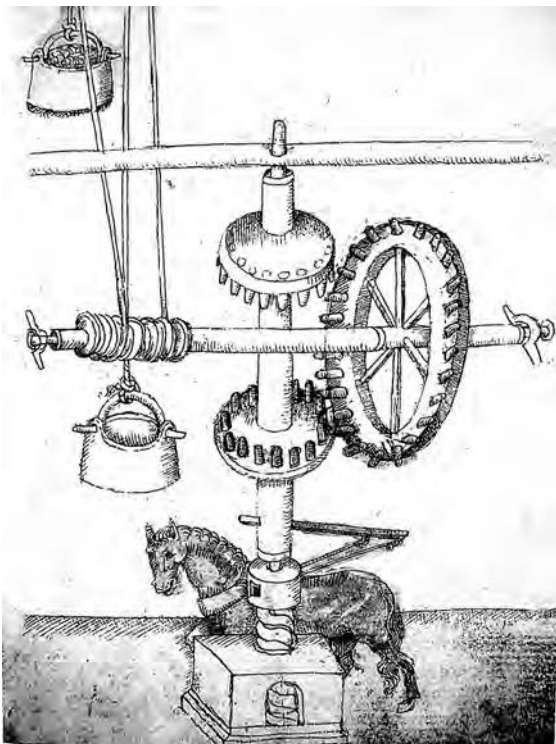
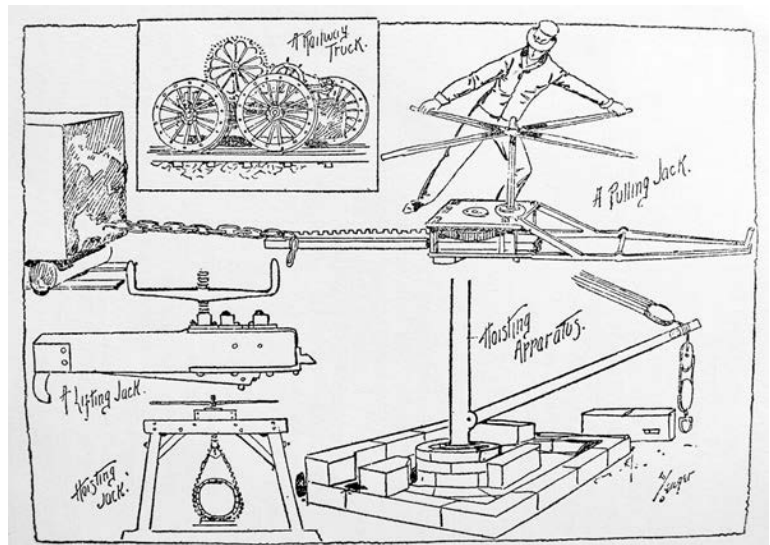


Figure 1 (left). Brunelleschi's ox hoist. This important and innovative lifting device made possible the timely completion of the main dome on Florence's cathedral Santa Maria del Fiore.

Figure 2 (below). The boom derrick (called the "Hoisting Apparatus" in the illustration) and jacks were invented by Solomon Willard and used in the quarrying and setting of granite for the Bunker Hill Monument.





diameter and up to a hundred and fifteen feet long, and were fit into derrick irons made in local foundries. The derrick sticks were shipped on three forty-foot flatcars from Oregon and Washington. Although quarrymen liked the elasticity of wood, by the end of the twentieth century steel derricks had supplanted the wood derricks. Most derricks were guy boom derricks (Figure

4) with up to a dozen 1½-inch diameter guy ropes radiating out from the guy plate at the top of the mast and secured to granite ledges or deadmen (large buried blocks of granite).

The terms cable and rope were used interchangeably to refer to steel wire cables. (We will use the term rope.) Often adjacent derricks were guyed together, from mast top to mast top, with “sky guys.” If there was not sufficient space for the guy ropes, a stiff-leg derrick (Figure 5) might be employed where the guys were replaced by two wooden poles secured to the top of the mast and anchored in the ground behind the mast. The boom, up to one hundred feet long, was attached at the bottom of the mast and swung as the mast rotated on an iron base called the “kettle.” A six-foot diameter cast iron wheel, the “bull wheel,” was fixed to the bottom of the mast and was used to rotate the mast and boom via the swing rope. The boom could be raised and lowered by the boom rope that came out of the derrick engine house roof and was reeved over the “rooster sheave” at the top of the mast. A derrick with a hundred-foot boom could reach any point within a circle of almost three-quarters of an acre in area. In the mid-1900s, a typical boom derrick (including hoist equipment) cost twenty thousand dollars.

There were three moving derrick ropes, the swing rope for swinging the boom (¾-inch diameter), the boom rope for raising and lowering the boom (¾-inch diameter), and the non-twisting fall rope (1¼-inch diameter) for raising and lowering the hook. Each derrick used about a mile of rope for guys, swing rope, boom rope, and fall rope. The fall and boom ropes, in constant motion, were replaced two or more times per year.

Early derricks were called dead-boom derricks (Figure 6) since they had no swing rope and the boom had to be manually swung by pulling sideways on the hook. The hoists for these early derricks had two drums, one for the boom rope and another for the fall rope, and were either



### Lifting Jacks

THESE Jacks are the result of many years' experience in building these machines. They are thoroughly well made; gears and pinions are all of steel and all bearings are brass bushed. The rack or lifting bar is made of hammered steel. The wood used in the construction of these machines is oak and face plates are Bessemer steel.

Numbers 1 and 2 are double-g geared and especially adapted for use by truckmen, in machine shops and stone yards. Numbers 3 and 4 are triple-g geared and designed for ordinary mill work and heavy work. All sizes have a lift of 1' 8". The jacks are known to the trade to some extent as "Maynard" jacks. We are now sole manufacturers of the jacks, having purchased the business of C. T. Maynard & Company.

No. 1, capacity 3 tons.	Height, 2' 8".	Weight, 70 lbs.	Code word: JACKO.
No. 2, capacity 6 tons.	Height, 2' 11".	Weight, 110 lbs.	Code word: JACKET.
No. 3, capacity 10 tons.	Height, 3' 4".	Weight, 160 lbs.	Code word: JACKY.
No. 4, capacity 15 tons.	Height, 3' 8".	Weight, 250 lbs.	Code word: JACKER.

Figure 3 (above). A page from a catalog at the turn of the twentieth century describing a double-g geared lifting jack.

Figure 4 (left). Guy boom derrick rigging. This derrick had a fall rope rigged with a “back block” so the lumber had only to deal with the weight of the hook.

Figure 5 (below). Stiff-leg derrick. This derrick was often used in tight spaces where there was not sufficient room for guy ropes.

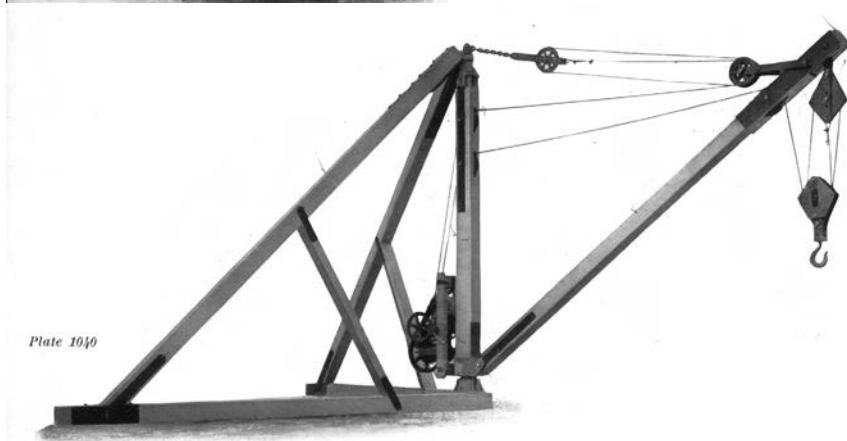
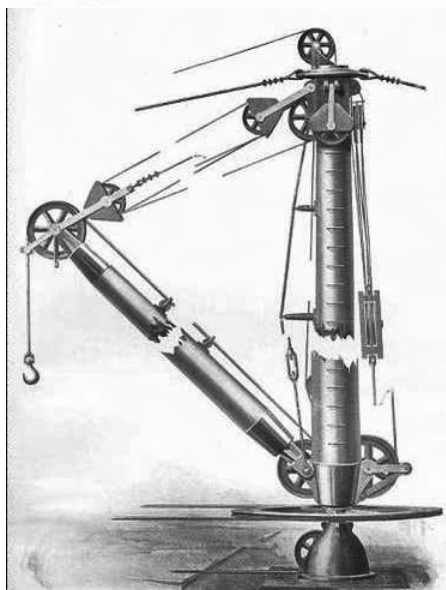


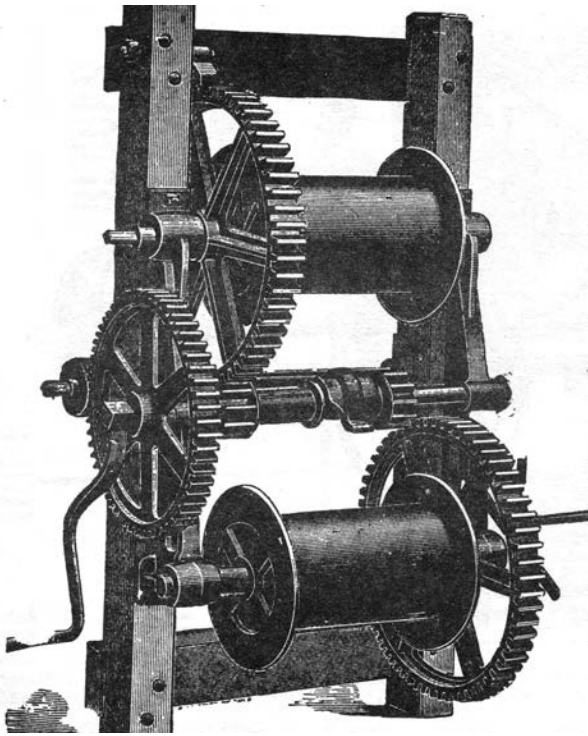
Plate 1040





manually-powered or horse-powered. The manually-powered hoist (Figure 7) was fastened to the base of the mast and had one or two crank handles for one- or two-man operation. A gear shift allowed power to be selectively applied to either the fall rope drum or the boom rope drum. Usually, the hoist had a pawl mechanism that prevented backward rotation of the drums. Many hoists had gearing for two speeds, fast for light loads and slow for heavy loads. Two men with the slow gear could lift five tons and with the fast gear twenty-five hundred pounds. Also, hoists usually had handles on the rims of the large gears that allowed rapid take-up of slack rope. A “lazy shaft” was often

provided so that the load (granite block or boom) could be let down without the crank handles turning. The horse-powered hoist (Figure 8) had a sweep that consisted of a long horizontal “sweep” pole that drove the drums through bevel gears. One or two horses were tethered to the end of the pole and walked in a circle. The sweep and hoist were normally located at some distance from the mast base so as to be out of the way of derrick operations. The rope from the hoist to derrick was recessed in a trench (note the trench in Figure 6). The horse-powered hoist provided much more lifting power—four to five tons in fast gear and twenty-five to thirty tons in slow gear.

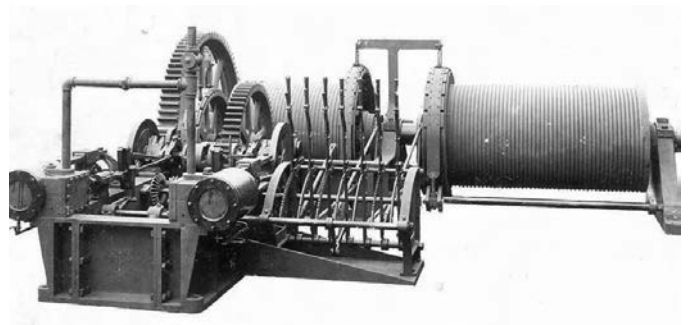
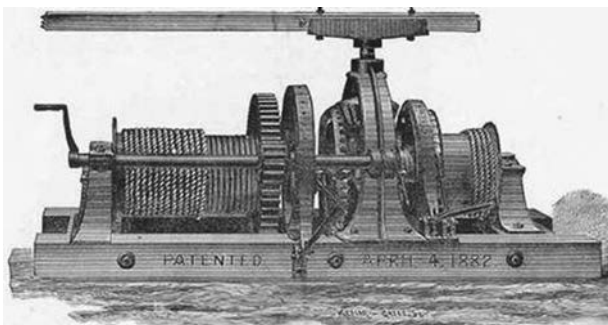


*Figure 6 (top). A dead-boom derrick at a small hillside quarry in Woodbury, Vermont (circa 1880s-90s). Note the trench carrying the ropes from the hoist to the derrick. A granite block is being lifted with a choke hitch.*

*Figure 7 (left). A manual, two-drum derrick hoist. This hoist was normally attached to the base of the derrick mast.*

*Figure 8 (bottom, left). A horse-powered, two-drum derrick hoist.*

*Figure 9 (bottom, right). A two-drum, steam derrick hoist. A smaller hoist for the swing rope, which requires less power, was normally separate from the main hoist.*





Later, hoists were located in an engine house and were driven first (circa 1870s) by steam, then later by compressed air, and finally by electric motor. The typical steam, compressed air or electric hoist (Figure 9) had two drums, one for the fall rope and one for the boom rope. A separate, smaller hoist was used for the swing rope. Each drum had a friction clutch on one side and brake on the other side. Each brake foot pedal had a holding ratchet. Pushing down on the foot pedal released the ratchet. Above each foot pedal was a hand lever to apply power via a friction clutch to the corresponding drum. Usually, the engineer sat in a seat suspended from a chain attached to a roller on a ceiling track. Although some large derricks could lift sixty to eighty tons, the typical capacity was forty tons. The average saw block shipped to the sheds weighed about twenty tons—leaving a wide margin of safety. Today, most wood derricks have been replaced by steel derricks with 110 to 160-foot tall masts and capacities ranging from 100 to 250 tons (see front cover).

The derrick was also used for moving equipment—for example, channel bars, drill bits, oil barrels and tanks, and warming sheds. Usually a head quarryman worked with each derrick. He was the one who called for the derrick. Also, he periodically checked the derrick ropes for wear or cuts. Given the distances involved and the high noise levels in the quarry, the head quarryman used hand signals to communicate with the derrickman, including signals to raise (thumb up with arm rising) or lower (palm down with arm falling) the boom, to raise (hand open with arm rising) or lower (hand bent at the wrist and palm down with fully-extended arm falling) the hook, and to swing the boom left (a sweeping motion with the left arm) or right (a sweeping motion with the right arm). A rigger had to grease derrick sheave (pulley) bushings twice a week, but later, following the introduction of ball bearings, that task was reduced to weekly. One of the sheaves, the “rooster sheave,” was located at the very top of the mast, and at first riggers had to climb up the mast ladder to reach it. The initiation of novice riggers often involved their making the scary climb up the mast to grease the rooster sheave. Some froze part way up and had to be brought down in a sling! In later years, riggers were pulled up by the derrick. Riggers were also responsible for the formidable job of moving the derricks as the locations of active quarrying changed. The boom would be raised to its maximum height, temporarily guyed and used to lift and move the mast.



Figure 10. Steel glut.

## Ropes and Cables

The saw blocks that were split by wedges and shims were “glutted out” with steel gluts (Figure 10) wedged between the blocks to make room for a rope to be put around them. Notches were cut in the block edges to hold the rope. After the rope was attached to the block, the rope was tightened by the derrick to see if everything was secure, and then the load was lifted out of the quarry.

Manila rope was used only for lifting light loads—rarely in the quarry. For the same breaking strength, hemp ropes were two to three times the diameter of wire ropes. For equal strength, steel wire rope was just as flexible as manila rope. Wire ropes were both more durable and more efficient (less friction) than hemp ropes. The typical wire rope had a hemp center with six surrounding wire strands, each strand with seven, nine, twelve, or nineteen wires. Wires for the best quality rope were made of crucible cast steel. Wire rope wear was greater for higher speeds and for smaller sheave diameters. Wire rope was used for boom derricks, cableways, and overhead traveling cranes. Seven-wires-per-strand rope (Figure 11) was normally used for standing ropes, such as guys, and nineteen-wires-per-strand rope (Figure 12) was used for hoisting (moving) ropes. The working load for ropes was usually kept at one-fifth or less of the breaking strain. Some example diameters and their corresponding breaking strains for H.H. Harvey’s Hercules hemp-center, nineteen-wires-to-the-strand, tempered steel, hoisting rope were:  $\frac{3}{8}$ -inch (eight tons),  $\frac{3}{4}$ -inch (29 tons),  $1\frac{3}{8}$ -inch (95 tons), and  $2\frac{1}{4}$ -inch (235 tons). In 1912, the Clyde Iron Works of Duluth, Minnesota, had for sale flattened-strand hoisting rope that presented a 150 percent greater wearing surface. This resulted in less wear to the rope and also less wear on the pulleys, sheaves, and drums over which the rope passed.

The hitches that wrapped around the stone and were suspended over the derrick, cableway, or crane hook to lift the stone were made of rope or chain. Chains could be formed into various sized loops to surround a stone by the use of a grab hook, round hook, or grab link at one end of the chain (Figure 13). However, ropes were considered safer than chains because a broken rope strand was usually easier to spot than a crack in the link of a chain. A quarryman requested a rope or chain of a certain size by





## THE CELEBRATED Leschen & Sons Wire Rope.

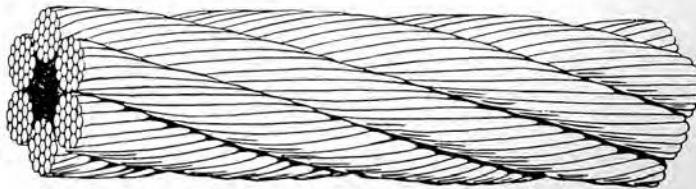
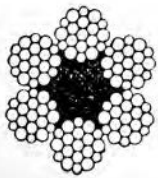
From the mill or from our store wholesale & retail.  
 Fig. 215.



Galvanized iron wire rope for Ships' Rigging, Guys for Derricks etc.  
 Six strands seven wires to a strand.

### AMERICAN STANDARD WIRE ROPE PLOW STEEL HOISTING ROPE

6 Strands—19 Wires to the Strand—1 Hemp Core



Diam. Inches	Approx. Circum. Inches	Approx. Wt. per Foot Pounds	Approx. Strength Tons of 2000 Lbs.	Working Load, Tons 2000 Lbs.	Diameter of Drum or Sheave Advised Feet	Price per Foot
2 <sup>3</sup> / <sub>4</sub>	8 <sup>5</sup> / <sub>8</sub>	11.95	275	55	11	\$ 3.00
2 <sup>1</sup> / <sub>2</sub>	7 <sup>7</sup> / <sub>8</sub>	9.85	229	46	10	2.50
2 <sup>1</sup> / <sub>4</sub>	7 <sup>1</sup> / <sub>8</sub>	8	186	37	9	2.00
2	6 <sup>1</sup> / <sub>4</sub>	6.3	140	28	8	1.58

the use of hand signals. For example, to call for 1<sup>1</sup>/<sub>2</sub>-inch rope—he passed his hand across his stomach; for 1<sup>1</sup>/<sub>4</sub>-inch rope he passed his hand across his throat; for 7<sup>7</sup>/<sub>8</sub>-inch rope he would with one hand grab the thumb of the other hand and wiggle his fingers; and for 1<sup>1</sup>/<sub>2</sub>-inch chain he faced both his palms toward each other.

Wire rope could be spliced very much like manila rope, and if properly done, the resulting splice was a very strong and secure join. To splice a rope, the ends were unraveled three feet back. The wire strands were taken two at a time one from each rope end, crossed over, wound around each other, and the ends tucked in so they wouldn't catch. Eyes could be formed by doubling back a rope over a thimble (to protect the rope from wear) and secured with multiple (usually five) rope clamps. Socket shackles (Figure 14) could be secured to the ends of a rope by pushing the unraveled end of the rope (cleaned with acid) into the socket into which molten zinc was then poured. The U-shaped shackle had a removable pin that was itself secured by cotter pins.

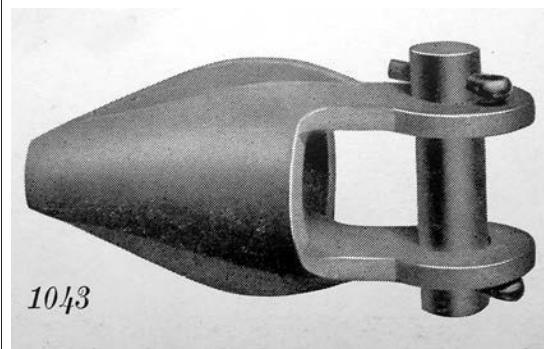
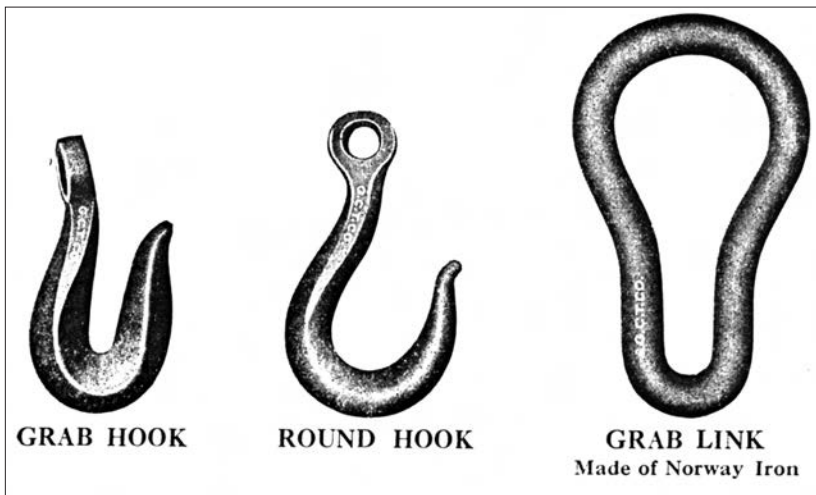


Figure 11 (top). Iron rope with six strands, seven wires to a strand. The center was hemp rope.

Figure 12 (middle). Steel rope with six strands, nineteen wires to a strand. The center was hemp rope.

Figure 13 (bottom, left). Grab hook, round hook, and grab link. Depending on the chain size, the grab hook could be 7<sup>7</sup>/<sub>8</sub> to 2 inches long, the round hook 1 to 2<sup>1</sup>/<sub>8</sub> inches long, and the grab link 3<sup>3</sup>/<sub>4</sub> to 2<sup>3</sup>/<sub>4</sub> inches long.

Figure 14 (bottom, right). Socket shackle.



A choke hitch (Figure 15) used a rope (approximately fifty feet long) with a socket shackle on one end and an eye on the other end. The rope was passed once around the stone and through the shackle. The eye was placed over the derrick hook. As the derrick hoisted the block out of the quarry, the choke hitch tightened. A baling hitch (Figure 16) used a rope (approximately fifty feet long) with socket shackles on both ends. One end was

looped around one side of the stone and through its shackle, and the other end was looped around the other side of the stone and through the other shackle. For this hitch, the edges of the block were notched just below the upper corners, and the rope loops were placed into these notches on each side of the block. The middle of the rope was reeved over the sheave of a shackle, which was hung on the derrick hook. Many quarrymen believed

this was more secure than the choke hitch since the two loops pulled in on the block from opposite sides and would hold the block even if there was a hidden crack. If a problem was going to occur, it normally didn't occur as the stone was being raised, but rather when it was stopped prior to the boom being swung.

The stone lewis (Figure 17) was a lifting device that fit into a hole cut wider at the bottom than the top. The stone lewis consisted of two iron wedges that were placed against the sloping sides of the hole and one or two flat iron pieces that fit tightly between the two wedges. A shackle was passed through holes in the tops of the iron pieces—securely holding their relative positions and providing a place of attachment for the derrick hook.

The stone lewis was often used to lift and set bases to avoid rope or chain damage to the finished stone. A lewis hole in the middle of the base would be



Figure 15 (above). A choke hitch.



Figure 16 (left). A baling hitch.

Figure 17 (below). Stone lewis.

Figure 18 (bottom, left). Pin (or chain) lewis.

Figure 19 (below, right). Lifting dogs.

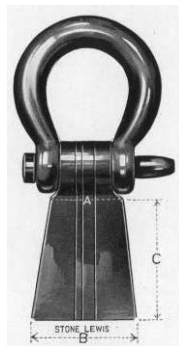


Plate 1015





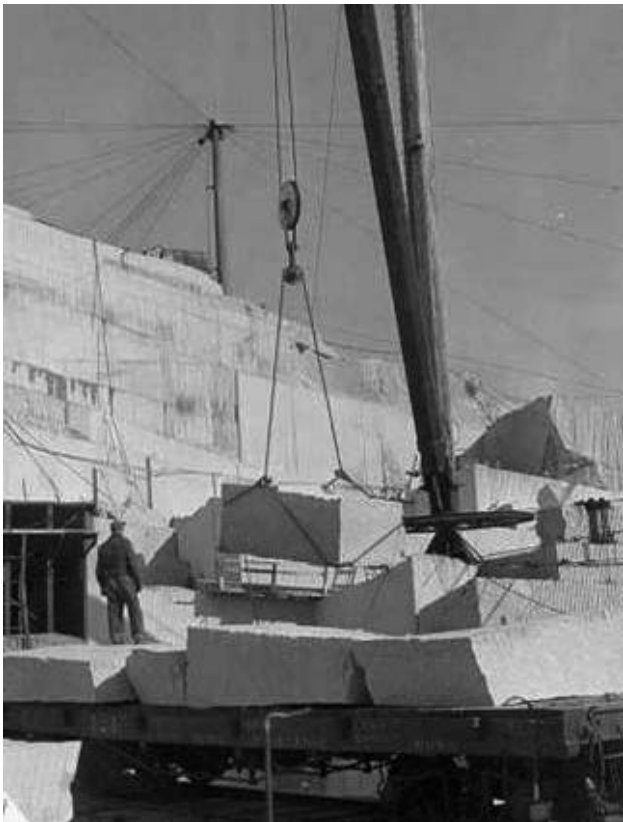


Figure 22. Trimming a quarry block with bull set and striking hammer.



**BULL SET**

We make Bull Sets which are second to none.  
The Heads of these Bull Sets do not batter over or split through the eye.  
From 8 to 16 lbs. Price 42 cents per lb.



**STRIKING HAMMER**

From 6 to 16 lbs. Price 50c per lb.

Under our process of Tempering our Striking Hammers have gained the highest reputation.

Figure 20 (above). Boom derrick loading a quarry block onto a flatcar.

Figure 21. Bull set and striking hammer.

If a block could not be moved enough to put the rope around it, two “tail holes” were drilled into the block corners with a jackhammer and two lifting chains were passed through these holes. Each chain was hooked to itself into a loop that was then passed over the derrick hook. This approach was also used if the block has a crack in it; a tail hole was drilled through the piece that might break off and it was secured by a chain through the hole to the derrick hook. Tail holes were mostly used on large pieces of grout. A tail (or loop) rope could also be used. One end of a twenty-foot piece of old boom rope was pushed through the tail hole, and the ends were tied together with a square knot, forming a loop. The knot was hammered flat, and the ends sticking out of the knot were hammered back at a sharp angle to secure the knot. The loop was then hung over the derrick hook.

## Trimming

A block could be lifted out of the quarry and immediately placed on a railroad flatcar for delivery to the finishing shed (Figure 20) or it could be temporarily placed in a stone yard at the edge of the quarry. Stones in the yard could be further reduced in size by trimming to fill current orders from the sheds. This was accomplished using a bull set and striking hammer (Figure 21). The bull set head had a narrow flat surface on one end that was placed against the stone and a beveled striking surface on the other. The striking hammer was similar to the drilling hammer, only larger at six to sixteen pounds. The bull set, usually held by the quarry foreman, was moved along the stone following a chalked line marking the desired edge of the stone. At each position, the bull set was struck by the

hidden by the stone above it. Brunelleschi used the stone lewis to lift stone for the dome of Florence’s cathedral. The pin (or chain) lewis (Figure 18) was a lifting device consisting of two pins that fit into holes drilled near opposite block edges. The bottoms of the holes slanted in toward the center of the block, and a chain or rope was passed between the pin eyes and over the hoisting hook. Today, the stone lewis and chain lewis are not considered safe and are no longer used. Lifting dogs (Figure 19) was a lifting device consisting of two hooks that grasped opposite sides of the block and a loop of chain or rope that passed through the hook eyes and over the hoisting hook. Lifting dogs are also not used any more—they can slip off the stone if it has hidden cracks under the dogs.



Figure 23. Woodbury Granite Co. White Quarry in Bethel, Vermont, with grout trestles in the background. Three grout piles are visible.



Figure 24. End-dump grout car.

quarryman with the striking hammer—knocking off a piece of granite (Figure 22). The trimmed off pieces were sent to the grout pile thereby saving on shipping costs to the finishing sheds.

### Lifting and Moving Waste Granite (Grout)

Railroad grout cars and flatcars were filled with large pieces of waste granite by derrick. Derrick-raised grout boxes were used for small pieces. The grout cars were run up onto a grout trestle, railroad tracks that ran on top of remotely-located grout piles, where they dumped their loads (Figure 23). Two types of grout cars were used—the end-dump grout car (Figure 24) that dumped grout over the end of the trestle and the side-

dump grout car (Figure 25) that dumped grout along the sides of the trestle. The dumping mechanism was powered by compressed air from the locomotive and was activated by a trainman after pulling on a release lever.

Grout could also be removed by a Blondin, an aerial crane or cableway (Figure 26), that carried a suspended grout box, or skip (Figure 27), from the quarry to a distant grout pile. Blondin was the stage name used by Jean François Gravelet, a French aerialist, who in 1859 gained fame by walking across a cable suspended 190 feet above the gorge of the Niagara River one mile below Niagara Falls (Figure 28). The cableway was supported by a horizontal or near-horizontal main rope (typically 2¼ inches in diameter), often several thousand feet long,



Figure 25. Side-dump grout car.

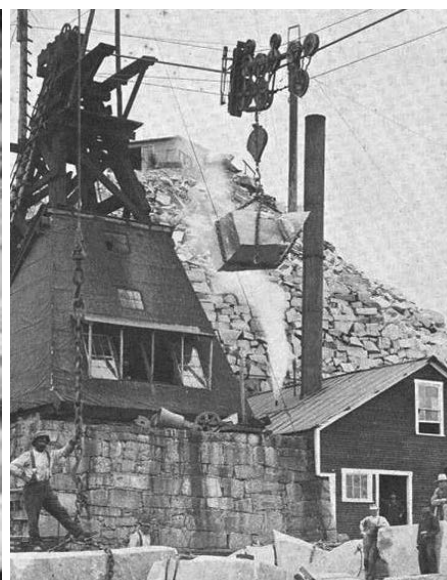


Figure 26. Cableway head tower and carriage.





©2013 The Early American Industries Association.  
 May not be reprinted without permission.  
 www.earlyamericanindustries.org

Figure 27. Grout box (or skip). Pulling on a rope attached to the eye of the hook-shaped device will dump the load.

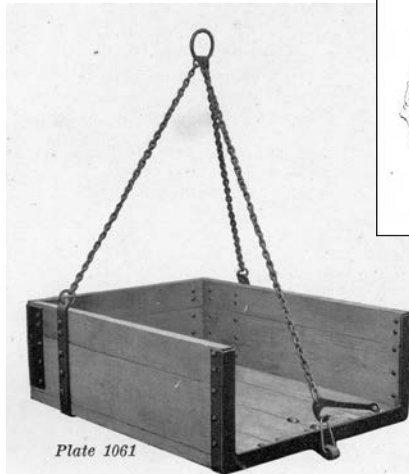


Plate 1061



Figure 28 (above). The movement of the carriage along the cableway reminded granite workers of the famous French aerialist Jean Gravelet, known as Blondin.

suspensae between a head tower and a tail tower. A carriage on wheels was driven in either direction along the main rope by a loop of rope called the traversing rope. A fall rope with fall block and hook was suspended beneath the carriage. A steam, compressed-air, or electric two-drum hoist, located at the head tower, drove the carriage in either direction and raised and lowered the fall block and hook (Figure 29). One cableway manufactured by Lidgerwood Mfg. Co. of New York City used a seventy horsepower hoisting engine that could lift an eight ton load on the fall block at three hundred feet-per-minute and could move the carriage at one thousand feet-per-minute. The traversing rope was wound four or five times around the traversing rope drum, so there would be no slippage. The traversing rope and fall rope drums were of equal diameters, so when both were revolving, the carriage could be moved while at the same time holding the hook at a constant height. Both hoist drums had brakes so the carriage could be held in position while the hook was raised and lowered and so that a load on the hook could be supported without applying power to the drum. Since at times the fall rope was slack (when there was no load on the hook), it was necessary to support the fall rope so the unloaded fall block and hook could be lowered and so the fall rope did not sag down and get in the way of quarry operations. The solution was the use of fall rope carriers, the number depending on the length of the main rope (Figure 30). The fall rope carriers were supported by a "button rope" that had regularly-spaced "buttons" clamped onto it that increased in size with increasing distance from the head tower. As the carriage moved away from the head tower, each carrier was in turn picked

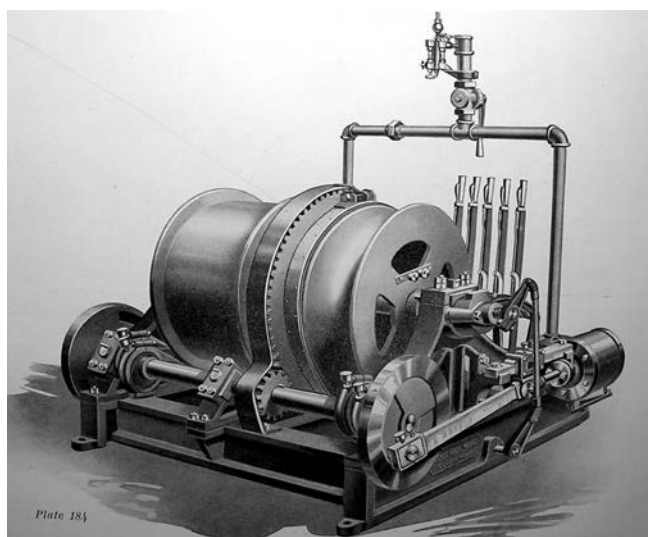


Plate 181

Figure 29. Cableway two-drum hoist. The large drum was for the fall rope and the small drum for the traversing rope.

up by and positioned at its own button, hence spacing themselves out and supporting the fall rope. When the carriage moved toward the head tower, the carriers were collected on a "horn" attached to the carriage.

Since the grout pile was distant from the cableway operator, it was necessary to design a mechanism that allowed remote-controlled dumping of the grout box. One commonly used mechanism set itself when the op-

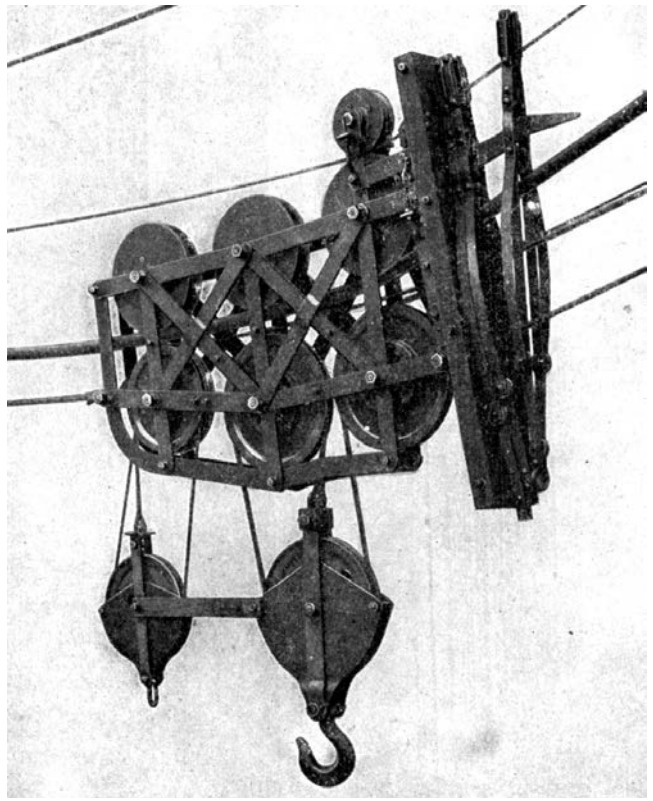
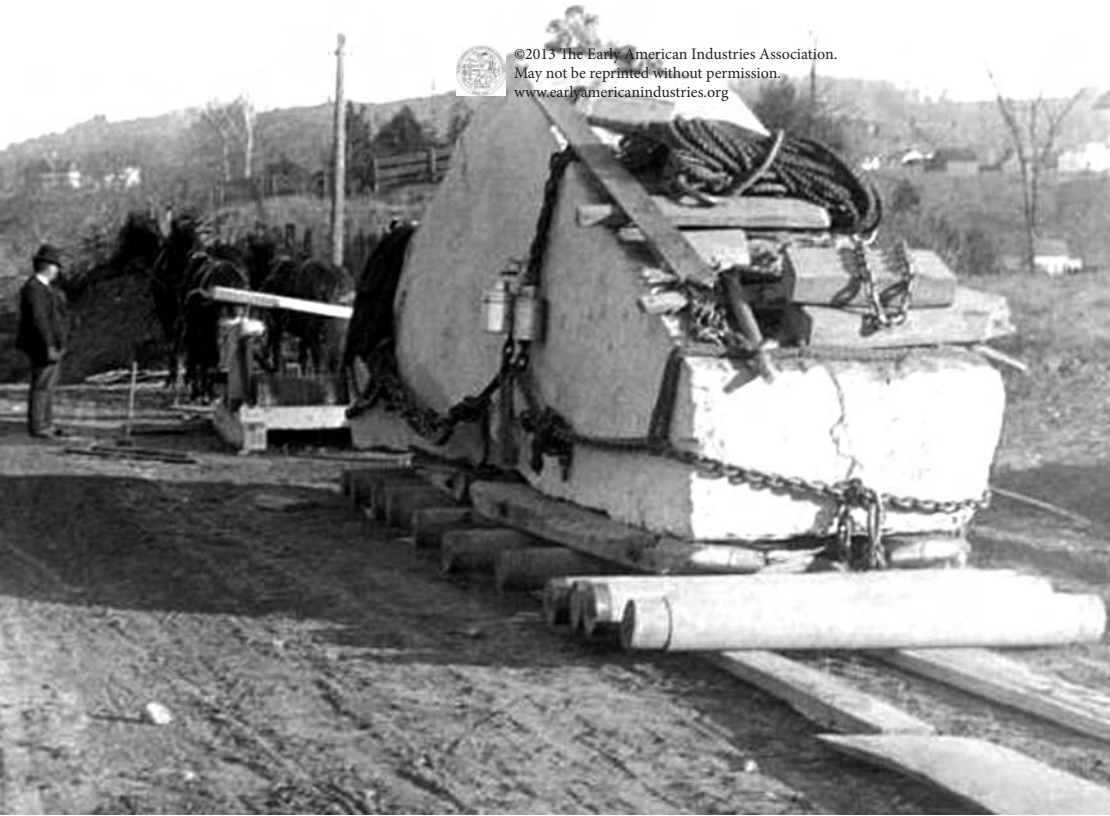


Figure 30. Cableway carriage showing the carriers for both the fall rope and the dump rope.



*Figure 31 (left). Moving a quarry block on wooden rollers. Note the block and tackle on top of the stone and the lunch pails hanging from the side.*

*Figure 32 (below). Hauling a quarry block by heavy wagon (Hardwick, Vermont, circa 1890s). Note the rear wheel brakes and the wheel drag being pulled behind by a chain. The long wooden pole was probably used to tighten the chains securing the stone to the wagon.*

erator raised the fall block above a certain point. When the carriage reached the desired dumping location, the operator lowered the fall block. As the fall block was lowered, the mechanism released at a certain point and the grout box was tipped—dumping the load of grout. Another solution employed an additional rope called the dump rope that was attached to the back of the grout box. The dump rope did not support the weight of the grout box but was only used to tip and dump the box.

The fall rope carriers were modified to also support the dump rope ( Figure 30). This solution required a third hoist drum for the dump rope that had two sections, one with a diameter equal to that of a fall rope drum and the other with a slightly larger diameter. When the carriage reached the dump site, the hoist was reversed, and the dump rope was shifted to the larger diameter drum section. Since the fall rope and dump rope drums rotated at the same speed, the dump rope was pulled in







faster than the fall rope and the grout box was tipped and dumped while the carriage was moving back for the next load. As soon as the load was dumped, the dump rope was shifted back to the smaller diameter section of its drum and the grout box returned to its level orientation, ready to be refilled.

For grout that had to be hauled over longer distances to be used for paving blocks, road foundations, railroad ballast, jetties, breakwaters, piers, and such, standard flatcars for large pieces or gondola cars for small pieces were used.

## Transporting from the Quarry

One of the earliest transport methods employed wooden rollers under a sledge-like base that supported the stone (Figure 31). Granite equipment suppliers were still selling wooden rollers well into the twentieth century—one advertising hardwood rollers up to twelve inches in diameter. Several workmen were assigned to moving rollers from the back to the front as the stone moved along. For muddy conditions, wooden planks were placed on the road as tracks for the rollers to run on. In ancient times, large gangs of men—often slaves—would pull and push the stone. In America, oxen and horses were used—the oxen providing the pulling power and the horses the directional control. For a large stone, the progress on rollers was very slow, often averaging as little as one mile per day. On very steep routes, a block and tackle might be used for short distances. The sledge, a sled-like conveyance without runners that

was pulled along the ground, was less efficient than the rollers but might be used to drag small stones short distances. If the ground was snow or ice covered, a sled, similar to a logging sled but with a flat bed, was an efficient means of transporting large stones.

Heavy-duty, horse- or ox-drawn wagons (Figure 32) with three or four axles and wide-rimmed heavy wheels were the most common form of granite transport over roads. One drawback was the crushed culverts and deep ruts that had to be constantly repaired after the heavy loads had passed. It was not uncommon for the heavy wagon to be immediately followed by a repair wagon with men and tools to repair the damage! To deal with muddy roads, granite teamsters often “double teamed”—one teamster would wait for the next to come along and they would combine their teams to pull the loads through the quagmire, one at a time. Downhill braking for extremely heavy granite loads required expert teamstering since horses do not tolerate a heavy load pushing on them from behind. Wagon braking was usually provided by brake shoes on the rear wheels activated by a chain or cable tensioned with a brake wheel (Figure 33). Braking was also accomplished by “wheel drags” placed under wagon wheels and “clog chains” placed under sled runners. (Note the wheel drag in Figure 32 being pulled behind the wagon.) Often the teamster would hitch horses behind the wagon or sled as well as in front to help brake the load. An out-of-control load could easily lead to the injury or death of horses and teamster as well as the destruction of the wagon or sled.



Figure 33. Granite teamster at a Woodbury, Vermont, quarry. Note the brake wheel.

As mentioned before, coastal quarries used coastal sloops or schooners (Figure 34) to ship to the major cities of the East Coast. Although some coastal schooners had four or five masts, most granite-hauling schooners had two or three masts. Some quarries used a “gary-mander” or “gallamander,” a vehicle with two large wheels (up to twelve feet in diameter) pulled by oxen or horses, to transport granite from the quarry to the schooners (Figure 35). The stone was suspended below the axle. A few inland quarries with a nearby canal could ship by canal barge. However, most inland quarries had to wait for the arrival of the railroad before they could be fully developed. The first quarry railroad, the Granite Railway at Quincy, Massachu-



## Jobs in the Granite Quarry (circa 1930s)

*The Superintendent* was in overall charge of quarry operations and production quotas.

*The Foreman* was in charge of one or more clustered quarry holes. He also selected and laid out stone to be quarried based on orders and kept track of hours worked by the quarrymen.

*The Marker* identified cleavage planes and marked drill lines with chalk. Typically, the foreman did this job.

*The Head Quarryman* was an experienced quarryman who directed a crew of quarrymen. He was usually the one who signaled to the derrickman. He was responsible for worker safety and was often paired with and instructed new quarrymen.

*The Driller* operated a large pneumatic quarry drill mounted on a channel bar frame to drill lines of lift and deep holes.

*The Bar Runner* assisted the driller by collecting dulled drill bits to be sharpened and supplying the driller with sharpened drill bits.

*The Powderman* loaded and shot explosives in lift and deep holes. Often, he was a head quarryman. The powderman was licensed by the state and received extra pay while loading and shooting.

*The Splitter* drilled plug holes using a plug drill and used wedges and shims to split the drilled rock. Or, he would use a jackhammer and iron gluts for splitting.

*The Breaker* trimmed quarry blocks to shed-required size using a bull set and striking hammer.

*The Lumper (or Loader)* put hitches on quarry blocks for lifting by the boom derrick.

*The Grouter (or Removing Crewman)* filled grout boxes and in general cleaned up the quarry. This was the lowest-skill job, usually filled by novice quarry workers.

*The Quarryman* was a non-specialized quarry worker who would act as splitter, breaker, lumper, or grouter depending on need.

*The Hoist Engineer* operated the boom derrick hoist in the derrick engine house following hand signals from the derrickman.

*The Derrickman (or Signaller)* constantly monitored quarry activities from his quarry edge shack and relayed signals from men in the quarry (typically the head quarryman) to the hoist engineer. The derrickman also operated the derrick whistle.

*The Rigger* erected, maintained, greased and moved boom derricks and cableways. The rigger also made up rope hitches and often supervised the lifting of very heavy loads.

*The Carpenter* built scaffolding, stairs, staging, ladders, shacks, etc. The carpenter was often considered part of the rigging crew.

*The Steam Fitter* installed, modified, and maintained piping systems for water, steam and compressed air. The steam fitter was often considered part of the rigging crew.

setts, employed a horse-drawn rail car that carried a suspended granite block (Figure 36). The principal granite-hauling railroad car was the standard flatcar, which at first was constructed mostly of wood and had a capacity of twenty to forty tons and later, as steel was used for the flatcars the capacity increased to up to one hundred tons.

For quarry railroads with moderate grades and gentle curves, a standard rod locomotive could be

used. As the grade increased, a saddletank locomotive might be needed in which the locomotive water tank was draped directly over the drive wheels to increase traction (Figure 37). For the steepest grades (7 percent and more) and tight curves, it would have been necessary to use a geared locomotive in which small wheels (thirty-two to thirty-six inches in diameter) were used, all of which were driven (Figure 38). Ephraim Shay of Haring, Michigan, was issued a patent in 1881 for the





Figure 34 (above). Granite-hauling coastal schooner Multnomath heading into Cape Ann, Massachusetts.

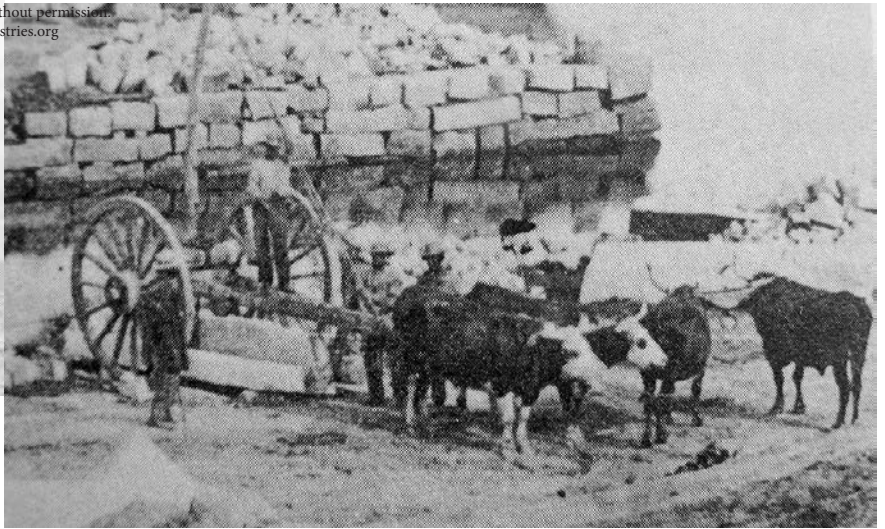
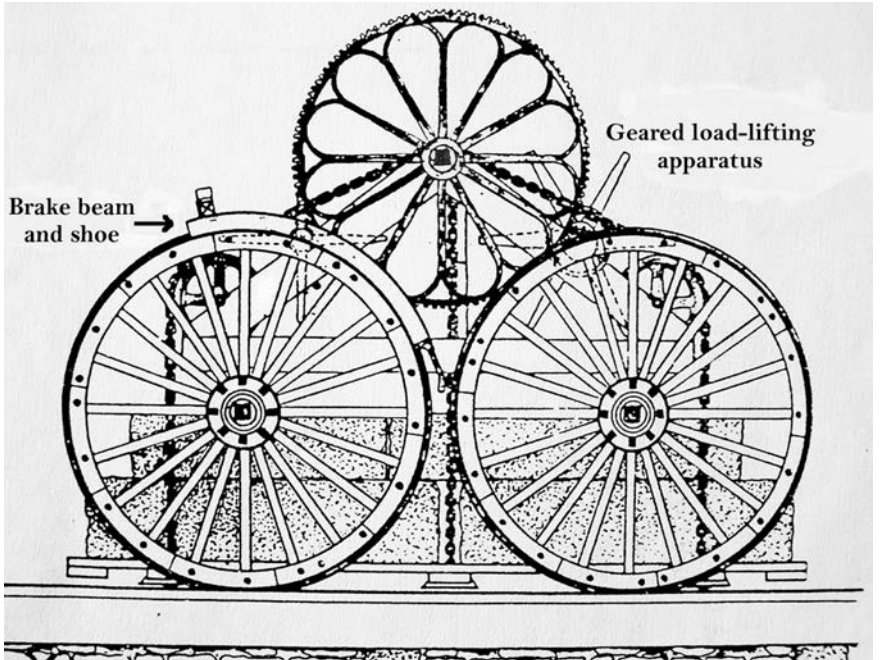


Figure 35 (right, top). Garymander at the Rockport (Massachusetts) Granite Company pier.

Figure 36 (right, bottom). Gridley Bryant's horse-drawn granite railroad car used on the Bunker Hill Monument Granite Railway.



geared locomotive in which the wheels were driven by vertically-oriented steam cylinders through a horizontal shaft with bevel gears, universal joints, and expansion couplings—allowing the wheel trucks to turn and follow the curved tracks and resulting in reduced track wear (Figure 39). The manufacturer was Lima Locomotive & Machine Co of Lima, Ohio. Shay locomotives, due to superior pulling power, had their principal application on steep-track lumbering and quarry operations. However, they were slow (twelve to fifteen miles per hour) and were used only where rod or saddletank locomotives were inadequate. By the 1950s, the diesel engine flatbed truck had become the primary granite transport from the quarry.

### Quarry Pumping

Water from rain or snow melt, from wet drilling, and from underground water seepage ran down into a sump hole at the very bottom of the quarry. From there it was pumped with a sump pump up into a holding pond at the quarry edge. The water in the pond was then reused in wet drilling or to replenish water evaporated from steam engines. Hot water from a boiler and storage tank was used during the winter for drilling. Quarrying in the early spring would be carried out in the upper part of the quarry—away from the spring flooding in the lower part. Each day, this water had to

be pumped out, and it often took until mid-morning before the bottom could be worked.

The Pulsometer steam pump, introduced in the early-1870s, was a popular and highly efficient quarry pump of the late-1800s and early-1900s (Figure 40). This pump was of a unique design, having no pistons, rods, cylinders, glands, cranks, or flywheels. It was a two-chambered cast iron pump that operated by the direct action of steam on water. One side acted as a suction pump as the steam condensed while the other side acted as a force pump as new steam under pressure was injected. Then, by the slight movement of a small rubber ball, the roles of the sides were alternately reversed so that the water was first suction pumped and then force pumped. For quarry pumping, the pump was suspended down a quarry wall with the suction pipe





Figure 37 (above). Saddle tank locomotive at the Wetmore & Morse quarry at Barre, Vermont.

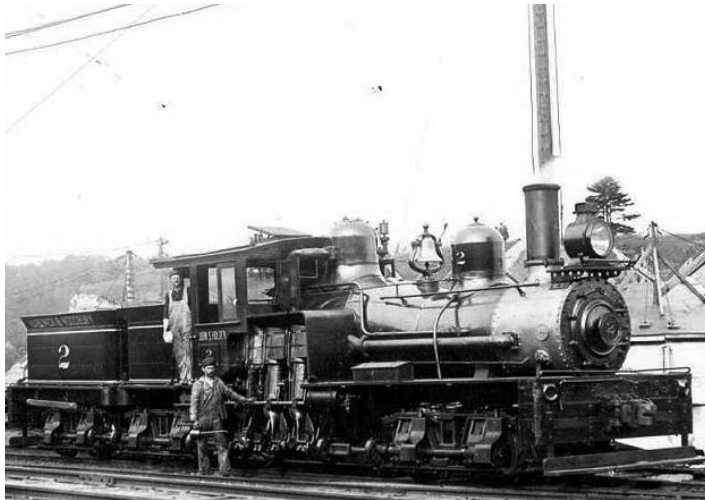
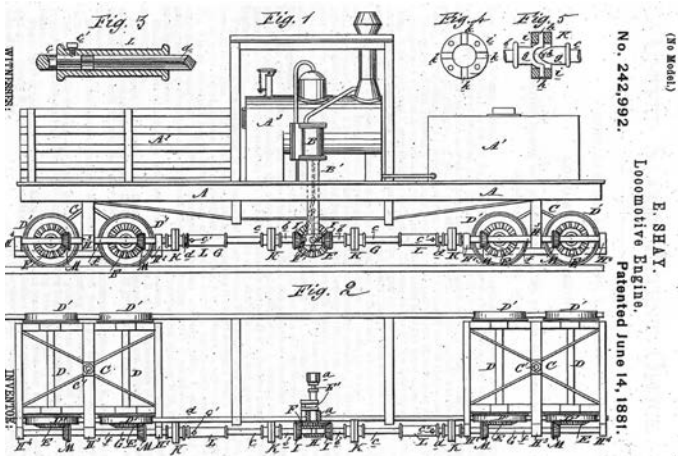


Figure 38 (left). Shay geared locomotive. Hardwick & Woodbury Railroad, Shay locomotive no. 2.

Figure 39 (left, bottom). Ephraim Shay's 1881 patent for the geared locomotive.



(ten to fifteen feet long) extending down below the pump into the sump hole on the quarry floor and a discharge pipe (fifty or more feet long depending on the available steam pressure) extending up above the pump to the quarry rim (Figure 41). If the pump was used for suction operation only, it could be driven by the exhaust steam from a steam engine at little or no extra fuel cost. The pump used rubber flap valves of a unique design that experienced little wear during operation. The rubber steam ball and valve flaps were the only moving parts. When the valves finally did wear out, the pump housing had access ports that allowed on-site replacement of the rubber flaps. The valves of a normal pump would quickly wear out under the onslaught of the highly abrasive slurry of water and granite debris.

The diaphragm pump, a currently popular quarry pump, consists of a cast iron housing divided into two chambers by a flexible diaphragm. Water enters the pumping chamber through a suction pipe and leaves through a discharge pipe. Both pipes are





fitted with one-way check valves so that water can only flow in through the suction pipe and out through the discharge pipe. The diaphragm is mechanically driven by a rod attached to its center. When the diaphragm is drawn away from the pumping chamber side, water is drawn into the chamber through the suction pipe and when the diaphragm is pushed toward the chamber side, the water is forced out through the discharge pipe. Like the steam pump, this is a long wearing design—the diaphragm and check valves requiring infrequent replacement. Centrifugal pumps are also used for quarry pumping.

### Air Compressing

Quarry air compressors were initially driven by steam turbines, then electric motors, and now often by internal combustion engines. A compressed air system had a relatively low efficiency (40-55 percent in the 1890s) due to heat loss during compression; however, the convenience of compressed air more than compensated for this inefficiency. The five large quarry air compressors at the Rock of Ages Barre, Vermont, quarry required a total of 2,200 horsepower to produce 9,000 cubic feet of 100 pounds-per-square-inch compressed air per minute or about 4 cubic-feet-per-minute per horsepower. A typical quarry drill required about 200 cubic feet of air per minute. An unloading valve was used when starting up a compressor, which took the load off until the compressor was up to speed. Initially, single-stage compressors were used. Today, two-stage compressors with intercooler (Figure 42) are the norm with the first stage producing 60 pounds-per-square-inch of compressed air and the second stage boosting the pressure to 100 pounds-per-square-inch.

Most compressors used forced oil lubrication. Compression both heats the air and raises its relative humidity. Excess water in the compressed air took the oil out of the drills resulting in excess wear and also the drills would freeze up in the winter. The compressed air was cooled between the stages in an intercooler and at an output cooler with a condensed water trap. Cooling water came from a cooling pond outside the compressor house. Compressed air pipes ran down into the quarry at several points. At the bottom, “bull hoses” carried air from the rigid iron pipes to the quarry drills. A crew of pipe fitters was employed to maintain and move water and compressed air pipes as the active quarry faces changed (Figure 43).

### Quarry Whistles

Derrick whistles were the primary signaling devices at the quarry. Each derrick had a whistle that was located on the derrickman’s shack at the quarry edge. The derrickman was in charge of the derrick; he had full view of the quarry operations and relayed derrick commands to the engineer who operated the derrick hoist. The derrickman could blow the whistle, and also a quarryman in the hole could blow the whistle by pulling on a

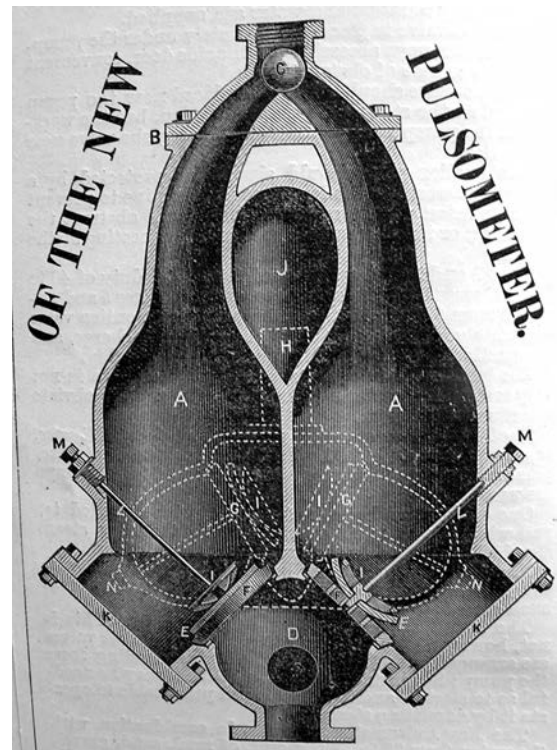
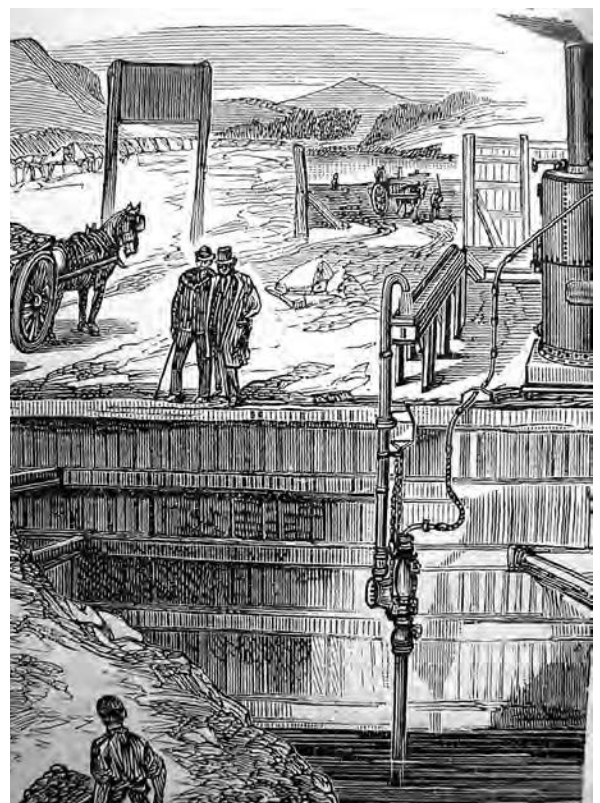


Figure 40. Sectional view of the Pulsometer steam pump. The only moving parts were the rubber flap valves (E) and the rubber steam ball (C).

Figure 41. Pulsometer steam pump shown in a pit pumping application.



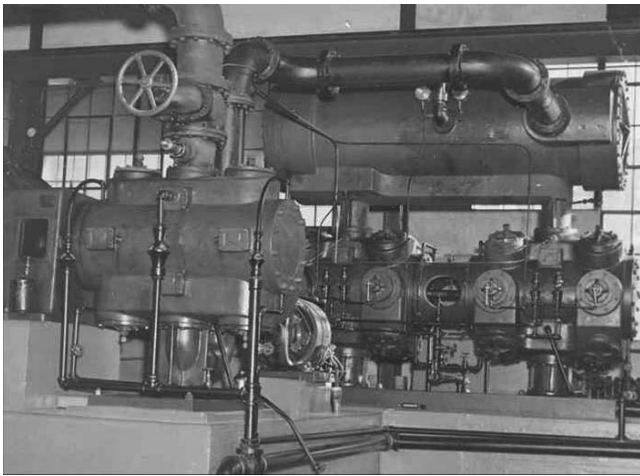


Figure 42. Air compressor at Rock of Ages, Barre, Vermont, with two stages, intercooler and forced oiling.

rope that hung from the whistle down into the quarry. Two long blasts signaled that a powderman was about to shoot. The first whistle was blown where the shoot would happen and then was repeated by the adjacent quarries. All quarry workers stopped working and took cover. They would actually go up out of the quarry in the ride box, a steel box (similar to but larger than a grout box) with a roof.

The ride box held a dozen or so quarrymen and was lifted by a derrick. There was a deadman switch on the derrick hoist. When the deadman was active the top speed of the hoisting cable was limited, and the derrick engineer had to keep his foot on a pedal. If he removed his foot, the brake was immediately applied to the hoist drum. There was a pin on the hoist that was locked in place to activate the deadman switch. When the pin was in place, a light went on outside the derrickman's shack. The quarry workers would enter the ride box only if the light was on.

A short toot was a signal to gain attention. Either the derrickman was warning that the derrick was going to move, and everyone in the hole looked up at the derrick to see what the situation was, or a quarry worker in the hole needed the derrick and wanted the derrickman's attention. The short toot would be repeated until the desired person's attention had been gained. A long blast signaled an injury. Either the derrickman or a quarry worker in the hole, whoever first saw the accident, would blow the whistle. The derrickman would direct the removal of an existing load in the fastest possible safe way and would send the ride box down into the hole for the injured quarry worker—often with a safetyman on board. Also, a call was made from the telephone in the foremen's shack to notify the office and alert medical personnel.

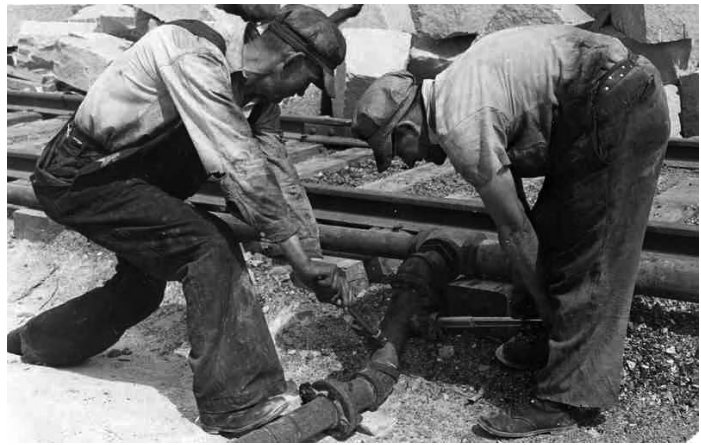


Figure 43. Pipe fitters circa 1950 working on a compressed air pipe.

In addition to the local derrick whistles at each quarry, there were large compressor room whistles that marked the divisions of the quarry worker's day:

- Five minute start of day warning whistle or starting whistle, which indicated that quarry workers should be down in the hole and dressed;
- Morning water whistle, which warned during the winter that hot water was going to be sent through the water lines. When hot water came out, each valve was closed down to a trickle;
- Lunch whistle and end of lunch whistle;
- Afternoon water whistle, which warned during the winter that the water lines were going to be blown out with compressed air; and
- Closing whistle, which was important since the ride box started out of the hole at exactly 3:30 P.M. and if a quarry worker missed it, he had a lot of ladders to climb. (Note the many ladders in the center and on the left of the cover photograph.)

*The third article in this series, which will be published in December 2006, will begin the description of the granite finishing process. Please see "Tools and Machinery of the Granite Industry, Part I" The Chronicle 59, no. 2 (2006): 52 for a list of references.*

### Author

EAIA member Paul Wood is a retired electrical engineer, who worked his entire career in the computer industry. He is interested in the tools, implements and machinery of the granite industry and of nineteenth- and early-twentieth-century farming in New England.







# The Chronicle

of the Early American Industries Association, Inc.  
Vol. 59, No. 4

December 2006

## The Early American Industries Association

*President:*  
Donald D. Rosebrook  
*Executive Director:*  
Elton W. Hall

THE PURPOSE of the Association is to encourage the study of and better understanding of early American industries in the home, in the shop, on the farm, and on the sea; also to discover, identify, classify, preserve and exhibit obsolete tools, implements and mechanical devices which were used in early America.

MEMBERSHIP in the EAIA is open to any person or organization sharing its interests and purposes. For membership information, write to Elton W. Hall, Executive Director, 167 Bakerville Road, South Dartmouth, MA 02748 or e-mail: eaia@comcast.net.

## The Chronicle

*Editor:* Patty MacLeish

### *Editorial Board*

Katherine Boardman  
John Carter  
Jay Gaynor  
Raymond V. Giordano  
Rabbit Goody  
Charles F. Hummel  
Walter Jacob  
Johanna M. Lewis, Ph.D.  
Michael H. Lewis  
Dan Reibel  
Bill Robertson  
Jack Whelan  
Frank White

*The Chronicle* welcomes contributions from anyone interested in our purpose. Submit articles to: Patty MacLeish, Editor, 31 Walnut Street, Newport, RI 02840. Telephone: (401) 846-7542; Fax: (401) 846-6675; E-mail: pmacleish@verizon.net. We prefer articles to be submitted on disk or electronically. Please submit in any commonly used word processing program. If typed, please double space.

## Contents

<b>The Hawley Collection—The First Ten Years</b> <i>by Joan Unwin</i> -----	125
<b>Tools and Machinery of the Granite Industry, Part III</b> <i>by Paul Wood</i> -----	130
<b>Mechanical Kitchenalia: Parers</b> <i>by Ken Turner</i> -----	152
<b>Departments</b>	
Stanley Tools by Walter W. Jacob <i>The History of Stanley Four-Square Household Tools Part II</i> -----	155
Plane Chatter by J. M. Whelan <i>Unfamiliar Cooper's Tools</i> -----	161
Letter -----	163
Book Review: <i>Historic American Roof Trusses</i> <i>Analysis and Drawings Shed Light on Trusses</i> by Robert Foley -----	164

## Covers

**Front:** Two examples from the Hawley Collection. A combination knife/fork made by Peck Brothers (1876–1889) is shown at top. Known as a Nelson knife, it was manufactured for people with manual disabilities, such as only having one arm, hence the name. A shield on the box lid is engraved with the owner's name P.C. Booth. According to street directories of 1884, Philip Charles Booth was part of the firm of Booth and Johnson, timber merchants. One dreads to think how the man came to require a Nelson knife! Below the Nelson knife is a saw, which has an ivory handle, was used for amputations. Joan Unwin describes the Hawley Collection at Sheffield University in England beginning on page 125. Photograph courtesy the Hawley Collection, Sheffield University.

**Back:** Ouch! One of the many window displays typical of those designed for Stanley Tools for its Four-Square line advertising campaign. The jaw vise illustrated was small, only 2-inches wide, but obviously could still pack a pinch. Walter Jacob's history of the Four-Square line continues on page 153. Photograph by Walter Jacob.

*The Chronicle* of the Early American Industries Association, Inc. (ISSN 0012-8147) is published quarterly by the Early American Industries Association, Inc. Elton W. Hall, Treasurer, 167 Bakerville Road, South Dartmouth, MA 02748. POSTMASTER: Send address changes to: *The Chronicle* of the Early American Industries Association, Inc. c/o Elton W. Hall, Treasurer, 167 Bakerville Road, South Dartmouth, MA 02748. USPO Publication Number 560-620. Periodical postage paid at New Bedford, MA, and at additional mailing offices. ©2006 The Early American Industries Association. *The Chronicle* is available on microfilm from: ProQuest, 300 Zeeb Road, Ann Arbor, MI 48106. Articles appearing *The Chronicle* are abstracted and indexed in *Historical Abstracts* and *America: History And Life*. Design: Patty MacLeish, Ideas into Print, 31 Walnut Street, Newport, RI 02840. Printed by Cayuga Press, 1650 Hanshaw Road, Ithaca, NY 14850.





# Tools and Machinery of the Granite Industry, Part III

by Paul Wood

## Granite Finishing

A small number of basic finished dimension stones made up the great majority of granite shed production. For gravestones and private monuments, there were dies (the main stone on which the lettering and ornamentation was cut), bottom bases, second bases, markers (a small stone set either flush to or raised from the ground level), posts (indicating the corners of a cemetery plot), boulders (natural-shaped stones, usually rock face finished), tablets (a die whose lower portion is buried underground), crosses, shafts, and columns. For mausoleums and vaults, there were roof stones and sidewall stones. For buildings and large public monuments, there were ashlar (four- to twelve-inch thick blocks that were carefully dressed on top, bottom, and sides so they could be set in a wall with uniform and tight joints), columns, capitals, steps, foundations, bas-relief panels, and statuary. The finished surfaces applied to these stones were rock face—an irregular natural looking surface produced by chipping out pieces of stone with a chisel; hammered—a powdered or steeled surface produced by hand or pneumatic bush hammer and of varying degrees of smoothness; polished—a mirror-like finish produced by a polishing machine; and carved—a wide variety of surface shapes and textures produced by hand tools, by a small pneumatic carving tool, or by sandblasting.

The finishing of granite involves only two basic processes—shattering and abrasion. Shattering is the crushing

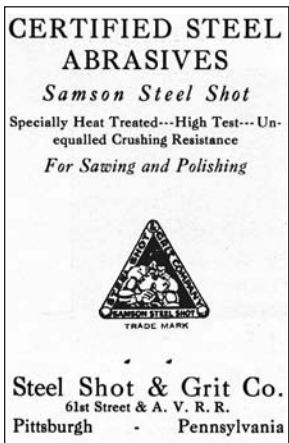


Figure 1. Steel shot abrasive was used for sawing and the initial stage of polishing.

and breaking of granite by the impact of a steel tool. The bull set, hand set, hand point, chisel, circular saw, surfacing machine, cutting lathe, and the first two stages of polishing machine use are examples of tools and machines that work by shattering. Abrasion is the wearing away of granite by an abrasive forced under pressure along the stone's surface. The gang saw, wire saw, Carborundum saw,



Figure 2. Horseshoe shed of the Hardwick Granite Co., Hardwick, Vermont, ca. 1895. Note the large doors to the granite working areas and the office door on the right.

grinding machine, polishing lathe, and the last stage of polishing machine use are examples of tools and machines that work by abrasion. Sandblasting appears to employ a combination of the two processes.

Much of the progress in granite finishing can be credited to advancements in abrasive technology. Natural abrasive materials were used from ancient times, including beach sand, whetstone dust, red limestone powder (Tripoli), emery powder, tin oxide putty, garnet dust, and iron filings. In the latter part of the nineteenth century, manufactured abrasives began to appear, including flint shot, cast iron shot, chilled cast iron shot, broken iron shot, chilled steel shot (Figure 1), broken steel shot, and emery bricks. During the twentieth century, artificially synthesized abrasive materials entered the market, including artificial diamonds, silicon carbide, aluminum oxide, boron carbide, cubic boron nitride, cerium oxide, tungsten carbide, and contained abrasive bricks. Contained abrasive bricks are molded blocks of abrasive contained in a binding-matrix material such as magnesite and chloride. They are used for the initial stages of polishing and are more economical to use than loose abrasives.

## Evolution of Shed Architecture

Many farmers harvested granite boulders from their fields and shaped the stone during the winter slow time in unused spaces in a barn or shed. The earliest



commercial stone sheds were designed around the boom derrick—either a round shed with a centrally located inside derrick that could reach any point in the shed or a horseshoe-shaped shed that defined a semi-circular yard with an outside derrick that could reach all the shed doors and any point in the yard (Figure 2). The final form was the straight shed having a rectangular footprint and designed for an inside overhead traveling bridge crane (Figure 3). One or two cranes could run along tracks that ran the full length of the shed and by this means reach any point in the shed. Whereas granite quarries were typically located at higher hilltop elevations where much of the overburden had been glacially removed, granite sheds were usually located in the valleys, often in an existing town, where worker housing and water or electric power were available.

Granite sheds needed to be provided with a variety of supporting services such as compressed air, water, heat, light, and dust removal. Compressed air was usually supplied via 4-inch diameter threaded iron pipes that went down both sides of the shed. Each pipe had a smaller-diameter steam pipe inside to warm the air and lower its relative humidity to prevent freeze up of pneumatic tool exhaust ports. Heating also yielded an added quantity of compressed air at a lower cost compared to that produced by a compressor. Smaller feeder hoses went to each granite cutter's or carver's workstation—called a banker—and surfacing machines with a shutoff valve for each (Figure 4). Water pipes, with either well or city-provided water, went down both sides of the shed. The horizontal and vertical grinders required large quantities of water to keep the dust down. Considerable water was also used in the tool grinding room.

Steam from boilers or exhaust steam from steam engines was piped to a heat exchanger. Fans blew air over the heat exchanger steam pipes and into a system of ducts that distributed hot air throughout the shed. On cloudy days or late winter days, the windows did not provide adequate lighting and electric lights were required. Lighting was provided by a row of large wattage light bulbs with porcelain reflectors. They were spaced at regular intervals down the center of the shed, hung under the roof ridgeline.

Before the installation of suction dust removal equipment, most granite cutting sheds had louvered cupolas along the roof ridgeline that were designed to vent airborne stone dust to the outside (Figure 3). Crane operators could open or close the vents by hanging rope-operated, hinged doors. Considering the amount

of airborne dust generated, these vents did little to alleviate the dust problem. After the installation of section equipment, the vent doors were always kept closed to conserve heat. For dust removal by suction, the dust laden air passed through a system of overhead ducts that exhausted into dust collectors/filters located outside the shed. State law required that the suction equipment to be periodically checked with a vacuum gauge.

Each granite company had a shed whistle operated by compressed air that was typically located on the boiler room roof. It blew four times a day: start of workday, start of lunch, end of lunch, and end of workday. All the shed whistles in a granite town took part in a wave of whistle blasts; each whistle had its own distinctive tone and was slightly out of sync with the others.

### Unloading the Quarry Blocks

Although today quarry saw blocks arrive on flatbed trucks, in the past they arrived at the cutting shed on railroad flatcars and were unloaded by a yard boom derrick located near the spur track. The block might be loaded onto a transfer car that was pulled into the shed on a standard gauge railroad spur track. (A transfer car is illustrated in Figure 19). Then, an overhead crane would transfer the block to a saw car that was winched into the gang saw on its own dedicated track. Or, the yard derrick might load the block directly onto a saw car if the saw car track extended outside the shed.

Large, multi-shed cutting plant operations required an efficient, high-capacity, materials handling facility, especially for building granite for which a single contract might involve thousands of pieces of finished granite. Often, this was provided by a large, rectangular runway or stone yard serviced by one or more overhead traveling bridge cranes, under which ran multiple railroad spur tracks (Figure 5). This arrangement allowed many flatcars and transfer cars to be simultaneously unloaded and loaded.

### Sawing

The ancient Egyptians used a copper-bladed, stone saw with sand abrasive. An early form of handsaw used in the American granite industry had a 2-foot long,  $\frac{3}{16}$ -inch thick iron blade with square teeth. It had an ordinary saw handle and a knob handle at the opposite end of the blade. Often there was an abrasive shot reservoir on top. One use for this saw was cutting grooves between individual reeds (thin parallel strips resembling reeds) on a large monument. In his book, *Stone Working Machinery*, M. Powis Bale notes that the Collis family, owners of a large marble quarry and early-eighteenth-century stone-work-





*Figure 3. Shed No. 1, the main shed of the Woodbury Granite Co., Hardwick, Vermont, ca. 1905-10, an example of a straight shed. The upper level with clerestory windows had the height to accommodate two overhead traveling cranes—one forty-ton and one twenty-ton.*

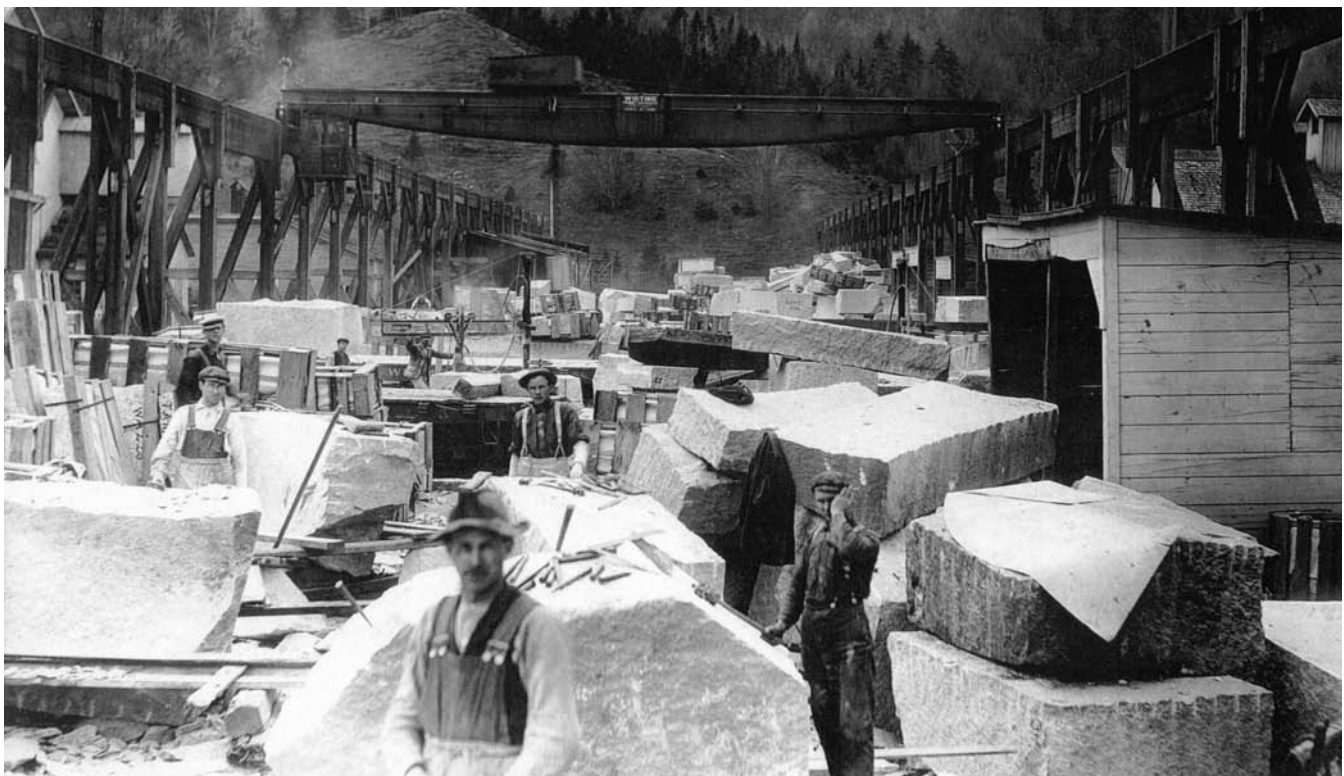
ing pioneers in Kilkenny, Ireland, employed gang saws that had twelve soft iron blades. The saws used sand and water abrasive and could saw ten to twelve inches per day, doing the work of about twenty hand sawyers. The blade frame was driven by a water-powered crank and pitman rod.

The gang saw was the first step for stone from the quarry (Figure 6). The objective of sawing is to cut the quarry saw block into slabs ranging from a few inches to a foot or more in thickness. A typical saw block was 10 feet by 5 feet by 5 feet. In 1909, the Woodbury Granite

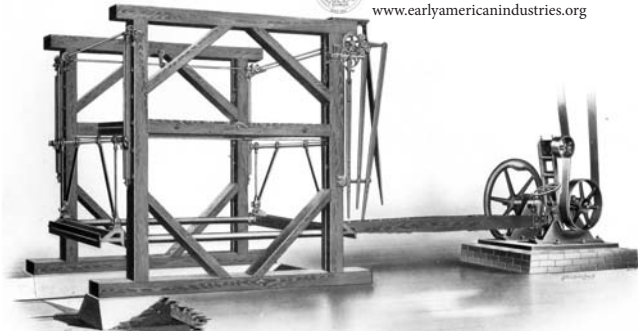


*Figure 4. Straight shed side bay with a row of granite cutter and carver bankers. Note the compressed air pipe running along the right-hand wall and the hoses leading to pneumatic tools, one of which can be seen resting on a stone in the foreground.*

Co. at Hardwick, Vermont, had two gang saws—one accommodating a maximum stone size of 10 feet by 8 feet by 6 feet and the other a maximum stone size of 16 feet by 6 feet by 7 feet. The hard way (one of the 5-foot by 10-foot faces) was marked at the quarry so the stone could be oriented in the saw such that the cuts were made along the plane of the hard way. Hence, the faces of the slabs produced by the saw were along the hard way plane and would become the faces of monuments. The close grain of the hard way results in the most beautiful



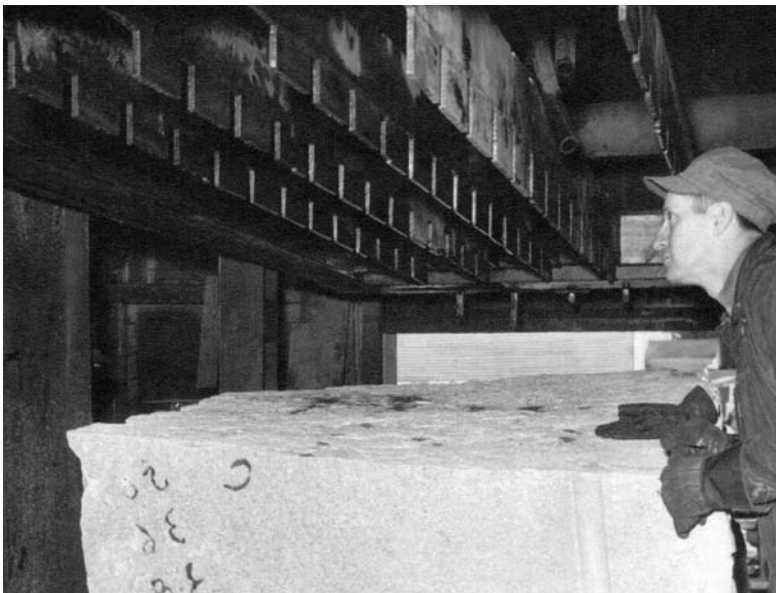
*Figure 5 (above). Runway at the Woodbury Granite Co., Hardwick, Vermont. This 575-foot by 75-foot stone yard was serviced by a 30-ton overhead traveling crane and intersected six railroad spur tracks.*



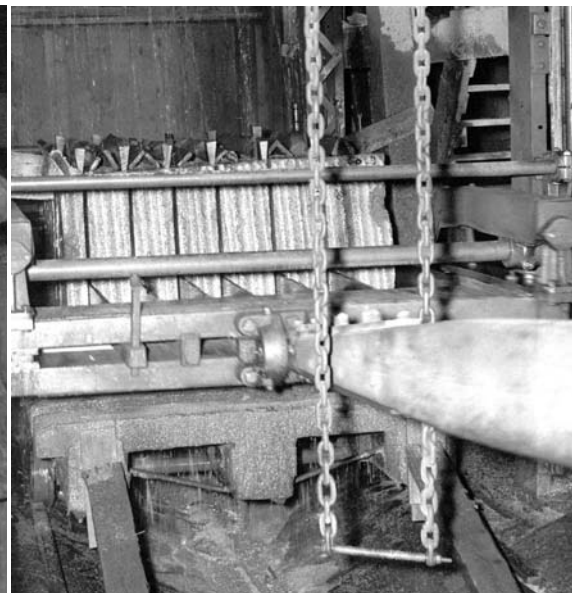
*Figure 6. Single-pitman, timber-framed gang saw manufactured by Lincoln Iron Works, Rutland, Vermont. A concrete hopper bottom collects abrasive for recirculation. Note the belt tightener on the right that allows power to be applied or removed from the saw.*

finished surface—polished or hammered. The gang saw consisted of a reciprocating frame with multiple cutting blades driven by a crank and pitman rod. The pitman rod was a long wooden shaft that transmitted power from the crank to the blade frame (Figure 6). The name was derived from the pitman that powered the timber-cutting down stroke of a pit saw. The main framework was initially wood and later iron. The saw used six or so steel blades 16 inches high and 16 feet long. The saw blade cutting edges had 2-inch-wide by 4-inch-deep rectangular notches spaced about 6 inches apart (Figure 7). Gang saw blades evolved from smooth-edged to notched and finally to brazed-on diamond segments. The gang saw was a noisy machine—making dragging and screeching sounds that could be heard a mile or more from the shed. They usually ran twenty-four hours a day with two-man crews.

The saw blades were tightened in the blade frame with wedges at the blade ends. Proper tension would be indicated by the ring of the blade when struck by the wooden handle of a shovel. Following cut marks made by the foreman on the saw block, blade spacing was set by placing wooden gauges between the blades. For example, eight blades spaced eight inches apart could yield seven 8-inch thick, 10-foot by 5-foot slabs from a 10-foot by 5-foot by 5-foot saw block. The saw block was positioned under the blades on a saw car that was secured by wooden blocks during sawing (Figure 8). The saw car tracks, which ran under each saw, were typically forty-five-pound rails laid seven to eight feet wide. In 1857, Andrews Merriman of Chicago, Illinois, patented (no. 24,478) a gang saw feed mechanism with four motor-driven dogged screws which forced the saw frame onto the stone through rigid hanging rods connected to the four corners of the frame. This greatly increased the sawing rate. The saw used abrasive steel shot stored in a tank above the saw. The abrasive was mixed with water and poured down onto the saw blades. The shot eventually fell into a pit under the saw and was recycled back up to the tank. If the blades started steaming, more shot was required. After sawing was complete, each slab was separated, chained, laid down and acid washed to prevent rust staining from the iron shot. Normally, the slab front and back was hammered or polished prior to splitting into dimension pieces. Since the gang saw produced a



*Figure 7 (left). A sawyer checks the blade spacing and tension of a gang saw.*



*Figure 8 (right). A gang saw with six blades almost finished with the cut. Note the saw car with two wooden braces to keep it from moving. Also, note the wedges in the saw kerfs to prevent the blades from binding. The abrasive slurry can be seen pouring onto the saw block and then down into the hopper bottom.*





## *A Typical Workflow for the Manufacture of a Monument (ca. 1930s)*

The following is a typical workflow for the manufacture of an eight-inch thick monument die with polished front, polished serpentine top, rock faced sides, and hammered back (see inset). The monument would also include sandblast-sunk lettering and hand-carved floral ornamentation and a die that rested on a granite base. There were minor workflow variations from one granite manufacturer to another.

- A yard boom derrick transfers a quarry saw block from a railroad flatcar to a transfer car. The saw block is pulled into the shed on the transfer car.
- An overhead crane lifts the saw block from the transfer car onto a saw car.
- The saw block on the saw car is rolled on tracks under the gang saw and the foreman marks the slab widths on the block depending on the orders in hand or expected.
- The block is sawn into slabs—one of which is eight inches thick.
- The slabs are separated and washed to remove any iron abrasive fragments.
- The overhead crane moves the slabs to a surfacing machine or polishing machine where a steeled or polished surface is applied to the front and back surfaces.
- The slab is then moved to a slab storage area in the shed.
- When an order is received, a shop card is prepared with a monument specification drawing giving the overall dimensions, the shape and the surface finishes.
- Full-size detail drawings of the lettering and carved ornamentation are prepared by a draftsman. These drawings are sent to the retail dealer for approval.
- When sufficient orders have accumulated, the shed foreman selects and tags a slab for the ordered monuments. (For our monument, one side of the slab has been polished and the other machine steeled.)
- Later, a lumper digs out the tagged slab—often having to move a half dozen slabs.
- The layout man (often the shed foreman) will then mark the cut lines on the slab with chalk for multiple dimension pieces—insuring that the slab is fully utilized with minimal wastage.
- The slab is cut into monument-size pieces using a slab splitter and striking hammer. For very thick slabs, wedges and shims may have to be used in drilled holes to split the slab.
- The monument is now moved from workstation to workstation by the overhead crane or on a transfer car if it needs to move between sheds.
- Following a pattern, a stonecutter roughs out the monument with a bull set and then a hand set (including the serpentine top) which takes the monument down close to the final surface. The stonecutter then squares up the monument with a pitching tool and chipper. Finally, he cuts the rock faced side surfaces with hammer and chisel.
- A horizontal grinder puts on the serpentine top with a semi-finish.
- A hand polisher or vertical polisher is used to polish the top.
- The monument is placed on a sandblast skid and wheeled into the stencil-cutting room where a rubber stencil is cemented to the polished front surface.
- The lettering design is transferred from the full-size detail drawing to the stencil.
- The stencil is cut; stencil pieces are removed to expose the granite areas to be sandblasted, and the lettering is sandblasted into the monument.
- Following the full-size drawing, a carver executes the ornamentation by hand.
- The monument is washed and crated at a washing and boxing stand.
- The crated monument is moved to the finished storage area to await shipping.



*A monument with polished face and polished serpentine top, rock face sides, lettering outlined by frosted panels, and shape carved ornamentation. The main stone on which the lettering and ornamentation is cut is called the die. Dakota Red Granite.*



very rough surface with saw marks, a hammered surface was applied by a surfacing machine prior to polishing. After sawing and polishing or hammering, defects were often discovered that were not apparent on the exterior surface of the quarry saw block. For monumental work, this often resulted in the rejection of one or more slabs. The manufacturer and quarry owner usually came to a financial agreement—typically sharing in the loss.

Initially, gang saws used hand-shoveled, sand abrasive. The introduction of abrasive elevators and cleaners for gang saws greatly increased the sawing rate. There were a dozen patents issued in the 1880s for abrasive (sand and water) feed mechanisms for stone sawing just to inventors in the Rutland, Vermont, area. At this time there were three Rutland manufacturers of gang saws (Lincoln Iron Works, Mansfield & Stimson Foundry, and F. R. Patch Manufacturing Co.) that were supplying the local marble industry. The water and sand (or chilled metal shot) abrasive mixture was lifted and mixed by means of a force pump. The pump used in abrasive feeds was a difficult problem due to the rapid wear out of the pump caused by the highly destructive nature of the abrasive being pumped. The common piston-type pump was not viable due to the need for constant repair and replacement of parts. Diaphragm pumps, the same design as previously described for quarry pumping, and centrifugal pumps were able to pump abrasives with very little wear and were used for most abrasive pumping ap-

plications. An abrasive distributor was introduced to feed abrasive to multiple gang saws so that one man could tend a dozen saws instead of just two.

Sand was adequate for soft stones such as marble, but for granite the use of chilled metal shot was required. In the mid 1870s, Struthers & Sons of Philadelphia was manufacturing 1/40-inch to 1/50-inch chilled iron shot for gang saws under a Tilghman patent. Chilling, the rapid cooling of the iron shot, hardened it and lengthened its abrasive life. Large granite blocks could now be sawn at the rate of three to four inches per hour and small blocks at twelve to fourteen inches per hour. (Using sand, the rate was about one inch per hour.) Three pounds of shot were consumed for every square foot of stone sawed. About 1885, John Harrison of Canada started his experiments with iron and steel shot abrasives. He later moved to England to be close to the sources of iron and began large-scale manufacture of abrasive shot widely used in the granite industry.

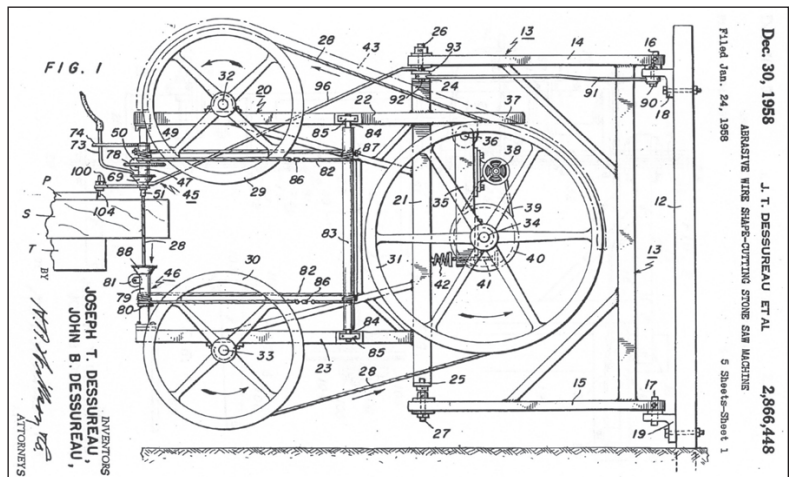
In the late 1940s and early 1950s, the wire saw replaced the gang saw for granite sawing (Figure 9). The wire cut faster, produced a narrower kerf—thus wasting less stone—and was quieter in operation. The wire saw might use a loop of single strand, multiple strand, twisted ribbon, or embedded diamond wire, but usually a two-strand twisted wire having a cross-section width of a quarter inch and a reverse twist every twenty-five to fifty feet was used (Figure 10). The wire loop moved



Figure 9 (left, top). A wire saw with four wires almost finished with the cut. Note the five sheaves, four of which are currently in use. Also, note the hoses conveying abrasive slurry into the saw kerfs. Figure 10 (left, bottom). Two- and three-strand saw wire.



Figure 11 (above). The 1958 Dessureau patent for a vertical wire contour saw. The saw is supported by a wall or post (12) and is guided by an operator handle (74). The frame articulates at two pivot points (16/17 and 26/27) and hence the cutting wire can reach any point on a horizontal plane. Abrasive is fed through a pipe (73) into a funnel (69) through which the wire passes.







at sixty miles per hour and a suspended weight of five to six hundred pounds maintained a constant tension in the loop. An automated down feed mechanism forced the wire down onto the stone and accelerated the cut. A flow of tungsten carbide abrasive was maintained into the cut by an abrasive pump. Joseph and John Dessureau of Barre, Vermont, one of the principal manufacturers of wire saws, were issued three patents for wire sawing: (1) improvements in automatic down feed for wire saws (1954, no. 2,674,238); (2) a wire design which claimed to have a longer life, to cut at substantially the same rate over its lifetime, to be easier to twist, to retain its twisted shape, and to retain adequate tensile strength (1958, no. 2,856,914); and (3) a machine to twist sawing wire so that it would be straight, free from torsion and have a tight uniform pitch. It also described a new method of producing twist reversals (1965, no. 3,225,798).

The saw wire loop was often four thousand feet or more in length to prolong the life of the wire. The wire was supported on a series of thirty to sixty inch diameter sheaves running as much as a half mile from the shed. (Five sheaves are visible in Figure 9.) Otherwise, the wire would

have had to be replaced too frequently and might wear out and break in the middle of a cut. For example, an eight hundred-foot loop would be worn out after approximately twelve hours of continuous sawing of an eight-foot-long cut. Typically, the wire had to be changed every day or every other day. The new wire was silver soldered to the old wire and pulled through the system of sheaves. Then, the new wire was silver soldered to itself—forming a loop. The saw operator was responsible for the wire replacement. A maintenance man was responsible for the maintenance and repair of the sheaves. Like gang saws, wire saws were run both day and night. An eight-wire saw was the primary saw for cutting saw blocks into slabs. The saw block was leaned against another block so that the slabs on that side would not fall over after having been cut. A chain from an overhead crane was attached to an eye in the floor to prevent slabs on the other side from falling over. An iron bar was used to tilt each slab, which was then slowly lowered by the crane and chain. Each block was then washed, numbered and stored.

The vertical contour saw was a specialized form of the wire saw, patented in 1958 by Joseph and John Dessureau (Figure 11). It had a short loop of vertically oriented wire driven by an electric motor, all of which was supported on a jointed framework attached to a shed post or wall. The framework allowed the operator to move the saw anywhere in a horizontal plane so that the vertical wire, like a jigsaw, could cut edges and holes of any shape or curvature. Cutting could also be directed by a template pattern. Abrasive was supplied to the wire by a pump that was located in the bottom of an abrasive sump pit. The operation of this saw was a dirty job—the emery abrasive flew off the spinning wheels onto the operator's face and into his mouth and got into every nook of his clothing! Later versions of the contour saw used diamond embedded wire. Today, the computer-controlled, horizontal, diamond wire contour saw is used for sawing complex curves and holes—for example, the Echo diamond wire profiling machine and the Pelligrini diamond wire saw.

The wire saw was gradually replaced by the rotary saw which initially had a six-to seven-foot diameter saw blade with removable, steel teeth so that worn out teeth could be removed and new teeth riveted on in the machine shop (Figure 12). The saw cut a  $\frac{7}{8}$ -inch kerf which was held open by wedges to prevent binding up of the blade. The height of the saw blade could be adjusted and could make up to a three-foot deep cut. The angle of the saw blade could be varied, enabling the saw to cut faces on slant markers, ridges on mausoleums, and obelisks. The

Figure 12 (right). Replaceable rotary saw teeth. New tooth segment on the left and worn out segment on the right. (See Figure 13).



Figure 13 (below). Steel rotary saw. Note the water sprayed on the side of the blade that washes the abrasive (entering from the pipe at the right) down into the saw kerf.





stones to be sawed were carried on saw cars which ran on a track under the saw. An abrasive pump in a sump pit recirculated steel shot up into an abrasive hopper. From the hopper, the abrasive poured through pipe into the saw cut and streams of water ran onto both sides of the blade to wash the abrasive down to the saw teeth in the bottom of the cut (Figure 13). These saws were usually run twenty-four hours a day. The whine and screech of the rotary saw could be heard for some distance outside the plant.

As early as the 1860s, H. & J. L. Young of New York City designed and manufactured a circular saw with embedded diamonds. In the early 1890s, the French company M.M. d'Aspine Achard manufactured a circular saw with one-half-carat, rough, black diamonds (\$5-\$10 each) set in the circumference. Achard's key contribution was a new setting technique in which the diamonds were retained even with the high blade edge speed—much higher than gang saw blades. The diamond saw yielded a very smooth sawn surface that could be polished without any intermediate dressing. It was estimated that the sawing rate was twenty to fifty times that of a gang saw using sand or iron shot. By the turn of the twentieth century, F. R. Patch Manufacturing Co. of Rutland, Vermont, was manufacturing a gantry diamond circular saw with a 300-pound, 6½-foot diameter blade that rotated at 500 rpm (Figure 14). The company touted its highly reliable diamond setting technique and promised only the best quality (hard) diamond borts. Now, computer-controlled circular saws with up to thirteen-foot diameter diamond segment edged blades carry out the large-scale initial sawing of the quarry saw blocks. The diamond segments are set onto the blade with a brazing technique. A twelve-foot diameter blade has about 160 diamond segments and can saw fifteen square feet per hour. The saw moves over a stationary saw block with a continuous flow of water on the blade for cooling, to reduce airborne dust and to flush out the cuttings. These saws run twenty-four hours per day, unattended during nights and weekends. The computer notifies the operator by telephone at home if there is any problem.

There are now available a wide variety of diamond saws, some hand-held and some supported on rails, arms, or gantries. Examples include horizontal saw, gantry saw, vertical curve saw, slab saw, radial arm saw, rail saw, chain saw, cut off saw, and band saw.

## Lifting and Moving Granite Within and Between the Sheds

Although occasionally a boom derrick similar to those used in the quarry might be used inside a round

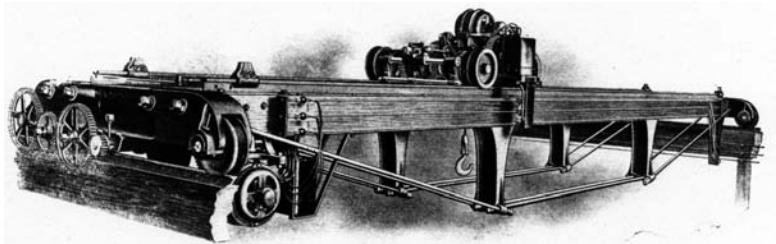
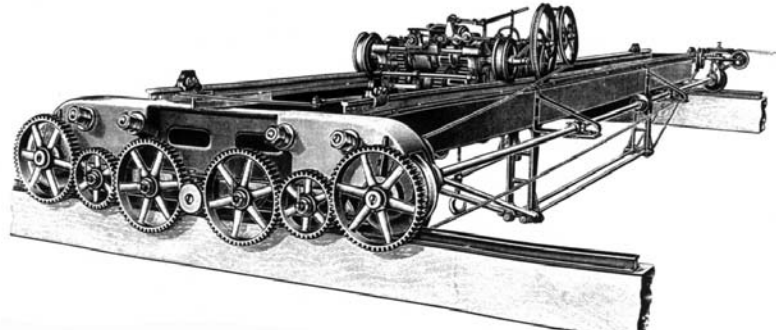
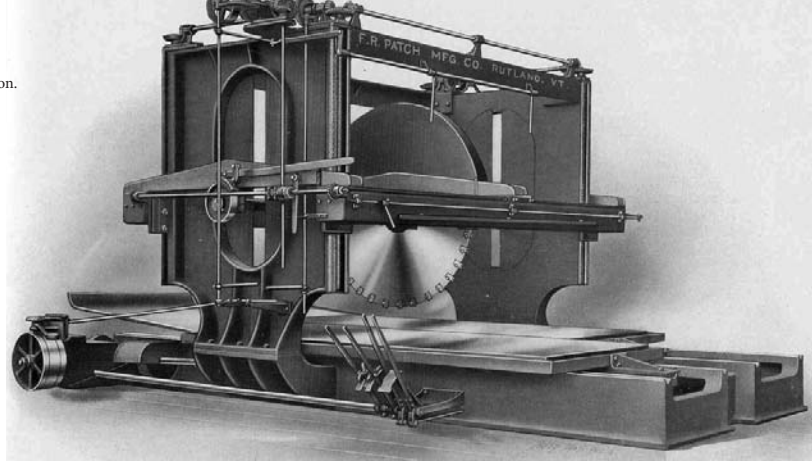


Figure 14 (top). Gantry saw with 6½-foot diameter, diamond, circular blade. Manufactured by F.R. Patch Co., Rutland, Vermont.

Figure 15 (middle). Rope-driven ("flying rope"), overhead traveling crane. The endless loop of rope can be seen entering the bridge and powering bridge wheels at the upper right. The rope enters and leaves the trolley at the two large pulleys on the right of the trolley and powers both the trolley wheels and the trolley hoist. The set of gears on the end of the bridge provides a means for the right-hand bridge axle to drive the left-hand axle.

Figure 16 (bottom). Electric overhead traveling crane. The bridge motor can be seen below the left end of the bridge. The trolley motor can be seen on top of the trolley. The bare copper wires can be seen running along the bridge and along the bridge tracks. The supports for the electrical contact wheels can be seen projecting below the trolley and bridge.

shed, it was the straight shed with its overhead traveling bridge crane that revolutionized the lifting and movement of granite in the shed. The manually powered, overhead bridge crane with a chain fall hoist was introduced into the American granite industry in the 1880s, apparently having originated in Scotland. The overhead traveling bridge crane consisted of a bridge that spanned the width of the shed (thirty to forty feet) and ran on tracks that went the entire length of the shed—one track on each side of the shed. A trolley ran back and forth on tracks that went the length of the bridge. A fall rope and hook was suspended from the







were introduced as replacements for chains and wire cables to hitch the stone to the crane hook (Figure 18). They were both more convenient and were less likely to damage the stone. The larger granite cutting plants had their own railroad spur track network that ran both between and within the sheds. Standard flatcars as well as transfer cars (Figure 19), pulled by cable or pushed or pulled by a locomotive crane or small switching locomotive, were used to move granite between sheds.

### Flat Surfacing

The bush hammer, a hammer for cutting and dressing stone, was invented and patented (patent without number) by Joseph Richards in 1828 (Figure 20). It was the first stone-working tool breakthrough in several centuries. The bush hammer (or ax hammer) had a set of removable blades (or cuts) on each side of the head—the greater the number of cuts the finer the dressing of the stone. The blades were held between two plates or cheeks by four bolts. The handle was also held in place between the plates. A number of additional hand tools have been used over time for manual surfacing including the peen hammer, hammer and point, scotia hammer, and hand bush chisel. To measure surface flatness, two pair of winding blocks were used (Figure 21). These 2½-inch high cast iron posts were placed on the granite block to be surfaced with a straight edge on top of each pair. The stonecutter sighted across the two straight edges. If the edges were parallel with each other, the stone was flat. If not, more stone was taken off until the edges became parallel. When the surface was flat, it was said to be “out of wind” (rhymes with “wind a clock.”) The plumb bob was also a key tool for the layout and aligning of granite blocks.

Alexander McDonald of Cambridge, Massachusetts, was issued an 1879 patent (no. 222,194) for the first successful stone-surfacing machine (Figure 22). It consisted of two stages—first a planer and then a bushing machine directly behind the planer. The first stage of the McDonald mechanical (non-pneumatic) surfacing machine used freely turning, eight-inch diameter-cutting discs. These discs were made of tempered steel with the working surface beveled to a sharp edge.

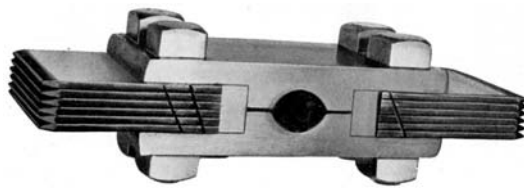


Figure 20. Bush hammer. The cuts can be replaced by simply removing the four bolts.

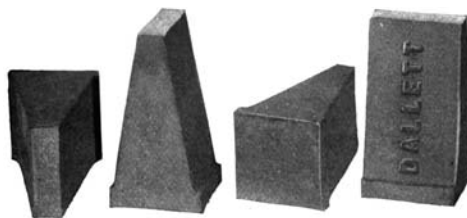


Figure 21. Set of four cast iron winding blocks manufactured by the Thomas H. Dallett Co.



Figure 19. Coal-fired locomotive crane shown loading and moving a transfer car. This locomotive crane acted as a switcher on the Woodbury Granite Co. (Hardwick, Vermont) railroad spur network. The lumber is on the left and the worker on the right is probably the crane operator.

The discs were mounted on two cutting heads, four to a head, which rotated at twenty to twenty-five rpm on vertical shafts. The heads were driven by a steam engine through a system of belts, pulleys and gears and required about eight horsepower. The stone moved on a driven carriage, at one to two inches per minute, under the cutters. About 150 square feet could be surfaced in one day. Blocks 18 feet long by 8 feet wide by 6 feet high could be accommodated. This massive machine required a space 26 feet high by 16 feet wide by 20 feet high. Only twelve of these twenty-eight-ton machines were ever built, at a cost of \$8,000 each. The McDonald surfacers were usually housed outside the main sheds since they were noisy and dusty machines. Unfortunately, the operators must have had extreme exposure to granite dust.

Later, circa 1890, pneumatic surfacing machines were introduced that used a single, powerful pneumatic hammer either attached to the end of a sliding horizontal bar—bar-

type— or mounted on a trolley that moved along a fixed horizontal bar—crane-type—(Figure 23). (The pneumatic hammer will be described later in “Roughing Out and Cutting.”) The horizontal bar was supported by a vertical post which was mounted on a cart with wheels. The bar could be raised or lowered by a hand-cranked winch and could rotate around the post in a horizontal plane, allowing the operator to position the tool anywhere inside a circle up to twenty feet in diameter. Thus, the pneumatic surfacer could handle very large surfaces, larger than could



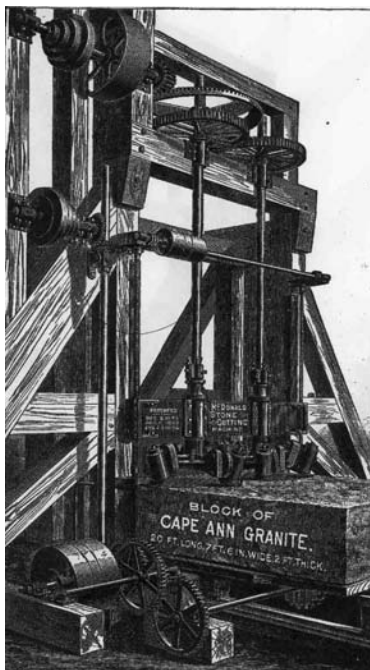


Figure 22. The McDonald surfacer, the first successful granite surfacer, ca. 1880s. Note the two four-disc cutting heads driven by vertical shafts.

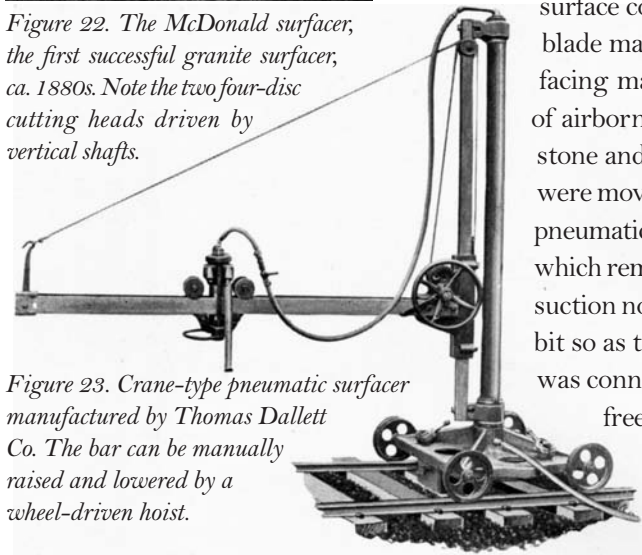


Figure 23. Crane-type pneumatic surfacer manufactured by Thomas Dallett Co. The bar can be manually raised and lowered by a wheel-driven hoist.

vibration of this tool was so severe that after a day's use, the stonemason's hands became numb due to lack of circulation—an affliction called "dead fingers." "The Bumper" was a major issue for the stonemason's union, and they succeeded in having it banned in many of their labor contracts. Today, some supply companies selling pneumatic tools offer shock absorbing (anti-vibration) leather gloves.

## Polishing

The ancient method of flat surface polishing employed a weighted iron plate that was moved back and forth over a stone using a sequence of ever finer abrasives: sharp sand, then fine sand or whetstone dust, then Tripoli (red limestone dust), and finally tin oxide putty. The earliest polishing machines were manual and were only suitable for small jobs. One example of a manual polishing machine consisted of a 68-inch long arm with a polishing wheel and handle at one end. The other end of the arm was pivot-mounted on a roller mechanism that moved back and forth on a 6-foot long track. By grasping the handle, the operator could

be produced by the gang saw. Pneumatic surfacers cost about \$3,500 each and were simpler and more reliable than the McDonald surfacing machine. James S. McCoy's American Pneumatic Tool Co. was one of the early manufacturers and supplied the Charles H. More & Co. of Barre and Montpelier, Vermont, with two of the first pneumatic surfacers. These were used on granite for the Iowa State Soldier's Monument, the largest monument of its type in 1894. The pneumatic surfacer used a four-point tooth chisel bit for the initial surfacing (Figure 24) and a nine-point tooth chisel bit or a bush chisel bit for the final surfacing (Figure 25). The surfacing machine bush chisel bit could have from four to ten blades—or cuts—of decreasing thickness; the more numerous and thinner the cuts the smoother the resulting surface. The bush chisel bit produced the following hammered surfaces: four-cut—suitable for steps, approaches, and upper building stories; six-cut—suitable for commercial and public buildings; eight-cut—suitable for memorials, mausoleums, building entrances, landscape art; and ten-cut—a velvety smooth surface suitable for monuments and statuary.

The surfacer's pneumatic tool required seventy-five psi compressed air and could surface about sixty square feet in nine hours, which was equivalent to a saving of eighteen dollars per day, or fifty-four hundred per year, over manual surfacing. It was said this machine replaced twelve men with hand bush hammers. A gang-sawed surface could not be used as an exposed surface since it was scored with blade marks and therefore had to be smoothed with the pneumatic surfacing machine. Since pneumatic surfacers were prodigious generators of airborne granite dust, they were later supplied with water to wet the stone and keep down airborne dust. Often during warmer weather, they were moved outside to alleviate the dust problem. By the late 1930s, most pneumatic surfacing machines were equipped with surfacer dust collectors which removed the dust by suction (Figures 26 and 27). The dust collector suction nozzle was positioned near to and moved with the pneumatic tool bit so as to suck up the highest percentage of produced dust. The nozzle was connected to a chip trap and suction fan via a flexible duct, allowing free movement of the surfacer bar and pneumatic tool.

The hand-held pneumatic surfacing, bushing and rough chiseling tool, called the hand facer, or "Bumper," was a heavy, powerful tool, weighing about eleven pounds and accommodating a large bit with a 1 1/4-inch diameter shank (Figure 28). The

Figure 24 (right). Four-tooth pneumatic surfacer chisel. This heavy-duty chisel bit has a 1 1/4-inch-diameter shank and is used for the first stage of rough surfacing.

Figure 25 (far right). Pneumatic surfacer bush chisel used for the final stages of surfacing. Note the built-in operator handle.



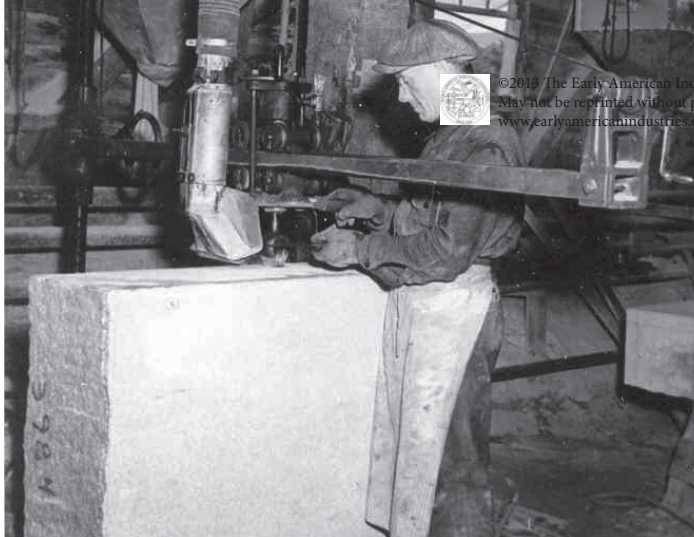


Figure 26 (above, left). Dust collector in action on a crane-type pneumatic surfacer.

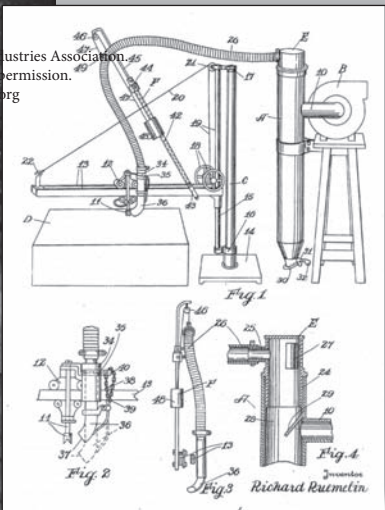


Figure 27 (above, right). The 1934 Ruemelin patent for the pneumatic surfacer dust collector. The Ruemelin Co. of St. Paul, Minnesota was the largest and most successful manufacturer of dust removal equipment, having patents on many of the basic designs. The flexible hose allows the suction nozzle to be attached to and move with the pneumatic tool without hindering its motion. The vertical can on the right is a chip trap that prevents granite pieces from entering and damaging the duct work.

position the polishing wheel to reach any point on a horizontal plane. The polisher was manually powered by a crank handle geared to the wheel. The polisher came with three polishing wheels: a 6½-inch diameter cast iron wheel with four spiral grooves for initial grinding, a 4-inch-diameter cast iron wheel with a smooth surface for closing up, and a 6½-inch-diameter wood surface wheel for fastening a buffing cloth for final polishing.

By the early 1700s, the Collis family of Kilkenny, Ireland, was employing powered polishing machines. The stone to be polished was placed on a table and an iron plate with sand and then limestone dust was driven back and forth on top of the stone by a water-powered crank and pitman rod. For the final polish, a buffer with oxide putty was used. Medad and Prentiss Wright of Montpelier, Vermont, were issued an 1878 patent (no. 203, 234) for the first of a long line of successful gate-type polisher designs (Figure 29). This patent described the fundamental characteristics of a post- or wall-mounted polisher with an articulated gate-like arm that could move 360 degrees and reach two polishing beds.

The gate- or arm-type polisher consisted of a horizontally oriented, cast iron polishing wheel supported by an articulated arm that allowed the wheel to be moved, via an operator handle, to any position in a horizontal plane. The arm framework, which supported a system of pulleys and flat belts to drive the wheel, was attached to a shed post or wall and depending on size had a radial swing of from five to eleven feet. Most polishers had bevel gears at the top so that the driving belt could be horizontal. A pair of cone pulleys allowed several polishing wheel speeds. The

framework and polishing wheel could be manually raised and lowered. Later designs included a powered mechanism to raise and lower the framework and wheel. This polisher was called the “Jenny Lind,” after the celebrated singer who toured the U.S. under the sponsorship of P. T. Barnum, because it emitted a pleasing humming sound. In 1896-97, H. H. Harvey of Boston was selling a “counterpoised” gate-type polisher for \$125. By the mid-twentieth century, polishing machines were powered by an electric motor. One popular design had the polishing wheel at one end of a centrally supported arm that was belt driven by a counterbalancing electric motor at the other end of the arm (Figure 30).

Polishers were used on surfaces prepared by the gang saw and the surfacing machine. Polishing took place in three stages: initial grinding with sand or iron shot; closing up with emery or Carborundum; and buffing with tin

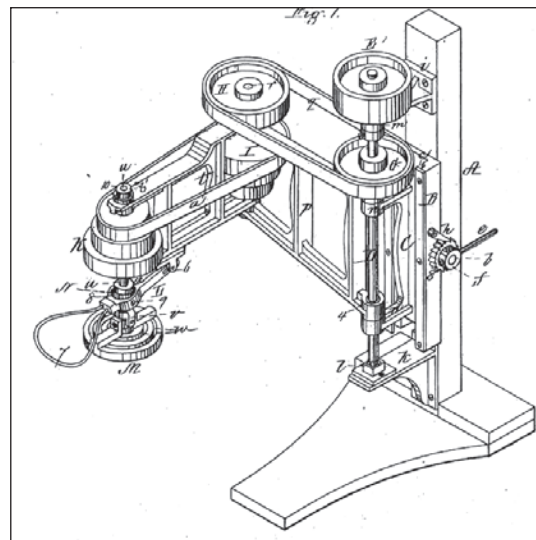


Figure 28 (above, left). The hand facer or “bumper” was a powerful hand-held pneumatic tool that could remove large amounts of granite in a short time. Its numbing effect on granite workers’ hands caused the granite workers’ union to lobby for its banishment.

Figure 29 (above, right). The 1878 Wright patent, the pioneering patent for a very successful line of gate-type polishers. The gate-like framework articulates at two joints so the polishing wheel (m) can reach any point on a horizontal plane and carries a system of pulleys and flat belts that power the wheel. Note the pair of cone pulleys (i and k) that provide three polishing speeds. Also note the ratcheted lever (e) that raises and lowers the frame.





Figure 30 (above, left). Polisher with counterbalancing electric motor (to the left and out of the photo). The granite worker is using a buffer to simultaneously polish the serpentine tops of three dies that are clamped together.

Figure 31 (above, right). Three types of polishing wheels: the shot wheel for initial rough polishing, the emery ring for closing up, and the felt buffing wheel for final polishing.

or zinc oxide. Abrasive consumption for the three polishing stages would be approximately:  $\frac{1}{2}$  to 1 pound per square foot of no. 3 iron shot;  $\frac{1}{4}$  pound per square foot of no. 80 Carborundum; and  $\frac{1}{40}$  pound per square foot of tin oxide. A variety of polishing wheels were used depending on the polishing stage and abrasive used: broken scroll, cast scroll, emery ring, concentric ring, contained abrasive brick, rope buffer, coco mat, and felt buffer (Figure 31). A typical 18-inch polishing wheel was designed to rotate at 200 rpm, required a 10 HP engine and, with an experienced operator, could polish thirty to forty square feet in an eight-hour day. Often the first-stage polishers had an abrasive pump that fed abrasive to the polishing wheel which allowed faster polishing so this machine could supply several other machines that were doing the closing up and buffing. During the last stage, buffing, the polishers used were first a very fine wheel and then a felt buffing wheel. The felt buffing wheel was a cast iron wheel with slots into which pieces of felt were inserted and wedged in place with wood pins.

Bed setters prepared multiple stones in a level bed so that they could be simultaneously polished by a large, gate-type polisher (Figure 32). (Polishing of an entire slab greatly simplified the setting process.) Bed setting required only relatively simple tools but did involve considerable skill and experience to do the job right. It was a dirty job and bed setters typically wore overalls. First, a stone was blocked with wooden blocks and wedges. A level was used in two perpendicular directions to insure a level surface. An iron pry bar was used to make the necessary adjustments. As additional stones were added, they were blocked and made level with the first stone and any other adjacent stones. A hatchet was used to drive wedges between the stones. Next, paper was stuffed into the cracks between the stones. Using a wooden paddle, the remaining cracks were filled with plaster level with the top of the stones. The plaster both helped to hold the stones in place and also to keep the abrasive on the surface and in action. Prior to final buffing, the top quarter inch of plaster was removed so it would not contaminate the buffer. Later designs of the gate-type polisher, for example those manufactured by W. A. Lane Co. of Montpelier, Vermont, in the 1890s, included an arm that could reach two beds. Thus, while one bed was being polished, the other was being set up so that the polisher could be in continuous operation.

The vertical polishing machine manufactured by the Concord Axle Co. and used circa 1890, was suspended from an overhead beam (Figure 33). It had a ten- to twenty-foot-long vertical main shaft with bevel driving gears and a universal joint at its top. The polishing wheel was attached to the bottom of the shaft with a second universal joint. The shaft and



Figure 32 (above). Two bed setters in overalls filling the cracks between set stones with plaster. Note the bed setter on the left holding a wooden plaster paddle.

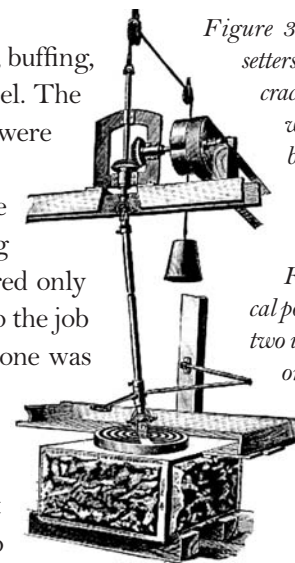


Figure 33 (left). Vertical polishing machine. The two universal joints visible on the main shaft allow the wheel to be tilted and to move anywhere on a horizontal plane.



Figure 34 (above, left). Granite cutter trimming an edge with help from a coworker.

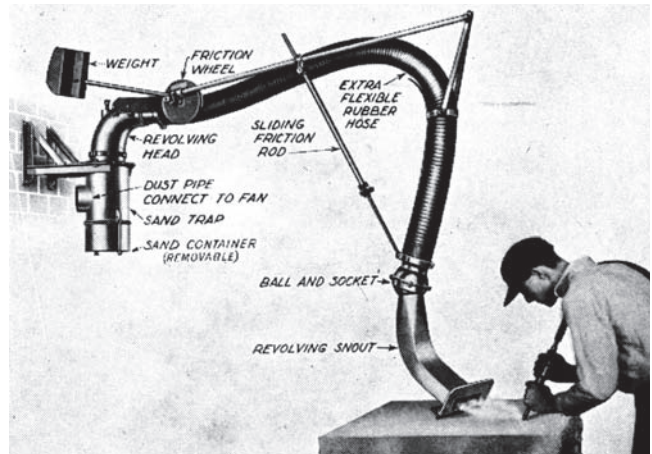
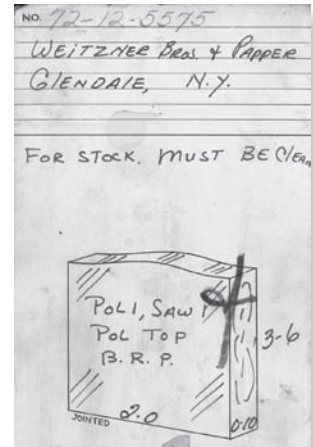


Figure 35 (above, right). Banker dust collector. The flexible duct's friction wheel and counter weight and nozzle with ball and socket joint allowed the granite cutter to easily position the nozzle close to the work.

Figure 36 (below). Shop ticket for a 2-foot wide by 3-foot, 6-inch high by 10-inch deep die with polished face (Pol 1), sawn back (Saw 1), polished top (Pol Top), and rock faced sides (B.R.P. = balance rock point). The bottom is jointed (flat) to sit on a base. The die was ordered by Weitzner Bros. & Papper, Glendale, New York.



polishing wheel could be raised and lowered and had a counterbalancing weight to make movement easy. This polisher had many degrees of freedom—the polishing wheel could be moved to any point on a horizontal plane and could be raised and lowered. The polishing wheel could also be tilted to any angle. This flexibility allowed the vertical polisher to work on curved as well as horizontal or slanted flat surfaces. In 1896-97, H. H. Harvey was selling a vertical polishing machine for \$100.

The hand polisher was suspended from a chain fall hoist attached to a trolley that ran along the top of the swinging horizontal boom of a crane. The hoist allowed the operator to raise and lower the polisher. The polisher head was belt-driven from an electric motor mounted directly on the suspended polisher frame. The operator stood on a four- to five-foot high wooden platform and could move the polisher to reach two workstations. He could be polishing the sides and top of one die while a second was being set in place. The hand polisher was used to polish the sides of large dies, to polish curved surfaces or tight places, and to polish out scratches and nicks.

Granite polishers have evolved into very sophisticated computer-controlled multi-head polishers with contained abrasive blocks such as the French-made Thibaut twelve-head continuous polisher that automatically moves the granite from one polishing stage to the next and can polish two hundred square feet of granite per hour. One of the most complex and most capable automated granite-working machines, the Thibaut GB110, grinds, shapes, routs, drills, and polishes.

### Splitting

Given a number of outstanding orders, the shed foreman would look for a slab of a certain thick-

ness and granite type to fill some of the orders. After measuring with a rule, he would ticket the selected slab. Later, a lumper would come along and dig out the ticketed slab—sometimes having to move a half dozen slabs to get at it. The layout man, who was often also the shed foreman, following dimensions on the shop tickets, would then mark the cut lines on the slab with chalk in such a way to insure minimum waste. Then he and a helper, known as the breaker, would cut it using a slab splitter and striking hammer. For a very thick slab, it might be necessary to drill holes along the chalk lines and split the slab using wedges and shims. Later, when wire saws and diamond circular saws became available, they were used to make these cuts. Today, the hydraulic slab splitter (“hydrosplitter”) is used for this job. It consists of a bed on which the slab rests and a pair of hydraulically powered knives, one positioned above and the other below the slab. The enormous forces (20,000 psi) applied to the slab by the knives splits the stone in a fraction of a second.

### Roughing Out and Cutting

Stonecutters were usually the most numerous of the granite workers in a shed. Each stonecutter worked at a banker—a bench consisting of saw horses or wooden blocks to support the stone being worked on. Normally, the stonecutter stood as he worked, with his whole body involved in the work. Occasionally, a neighboring stonecutter might help (Figure 34), and for a really large stone, two or more stonecutters might





© 2013 The Early American Industries Association.  
 All rights reserved. No part of this publication may be reproduced without permission.  
[www.earlyamericanindustries.org](http://www.earlyamericanindustries.org)

work at the same banker. Each banker was supplied with compressed air through a hose with various couplings connected to the stonemason's pneumatic hammer. A banker might also be supplied with water, and by the late 1930s, had a suction device, called the banker dust collector, for the removal of airborne granite dust (Figure 35). Carvers also worked at bankers and, although fewer in number, usually worked side-by-side with the stonemasons.

After a stone had been sawn, flat surfaced, polished, and rough split, the stonemason roughed out, trimmed, and finished the stone using a variety of hand and pneumatic tools. The stonemason worked from a diagram or

“shop ticket,” which included a working drawing of the finished piece along with dimensions and finishing information (Figure 36). The shop ticket had a three-dimensional (isometric) drawing of the die, base, and marker, and gave its overall dimensions (height, width, and depth) in feet and inches. Defining dimensions were given for such shapes as serpentine or oval tops, scotias, checks, chamfers, margins, etc. Finishes were specified for each surface such as polished, rock-faced, steeled, planed, honed, or wire-sawed. Often the finish was also indicated graphically—for example, parallel lines for polished surfaces and arcs for rock faced surfaces.

To guide the roughing out, trimming and finishing, the stonemason laid out the lines and surfaces on the stone from the

HAND SET			
Stock	Length	Blade	Price
1"	8 1/4"	2"	
1 1/8"	8 1/4"	2"	
1 1/4"	8 3/4"	2"	

HAND CHIPPER			
Stock	Length	Blade	Price
7/8"	8 1/4"	1 3/4"	
1"	8 1/4"	2"	

HAND TRACER			
Stock	Length	Blade	Price
7/8"	8 1/4"	1 3/4"	
1"	8 1/4"	2"	
1 1/8"	8 1/4"	2 1/4"	

HAND CHISEL			
Stock	Length	Blade	Price
1/2"	8"	1/2"	
3/4"	8 3/4"	3/4"	
7/8"	9"	7/8"	

HAND POINT		
Stock	Length	Price
3/4"	9"	
7/8"	9"	

Figure 37 (top). Granite cutter using a hand hammer and hand set to trim a monument along a traced line.

Figure 38 (left). Three granite cutter's hand tools: hand set, hand chipper, and hand tracer.

Figure 39 (above). Two granite cutter's hand tools: hand chisel and hand point.

working drawing using a straight edge, carpenter's square, stonemason's chalk and chalk line, and African marking camwood, a tropical wood used like chalk to mark granite surfaces. For monumental work, the stonemason did not usually work to fine tolerances, but his flat cut surfaces had to be uniform and without obvious waves or irregularities and his angles “eye true.” However, for fine mausoleum and building work, tolerances of 1/32 inch, and sometimes even 1/64 inch, were often maintained so that the blocks and ashlars would fit together with tight seams. This degree of accuracy required machine finishing.

First the stonemason, with the help of a neighboring cutter, would rough shape the stone with a bull set. Next, the hand tracer was used to trace the chalk-marked lines along which the stone would be trimmed. A two- to three-

pound steel hand hammer was used to strike the hand tools. The die front and back were used to square up the sides, top and bottom. Then, a hand set or heavy-duty offset hand set was used to trim the stone to size along the traced lines (Figure 37). This was followed by the hand chipper to crisp edges of the stone (Figure 38). A straight edge, up to eight feet long, with lead plugs so as not to damage the finished surface might have been clamped onto the stone along the edge to guide the chipping process. Or, as in Figure 34, a coworker might have held a straight edge. Next, a hand point or hand chisel was used for knocking off high points on the sides and top (Figure 39). Finally, a hand bush chisel or bush hammer was used to smooth the surface and close the grain. The stonemason often prepared the stone for the carver—for example, removing and finishing

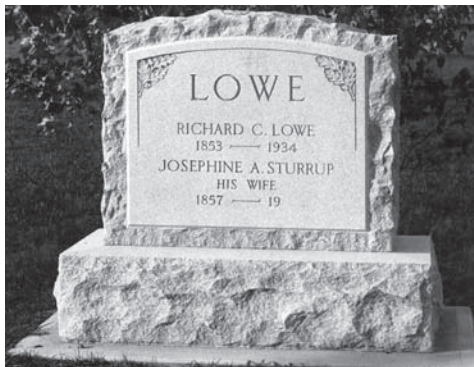


Figure 40. A rock-faced monument showing the contrast with a steeled raised panel.



the background around a to-be-carved bas-relief. If the stonemason had sufficient skill, he might use a chisel to cut rock face (or rock pitch) surfaces, or this might be done later by a carver. Used with restraint, rock face surfaces can add a natural dignity to a monument. The simple rugged broken surface can stand in contrast to a hammered or polished surface (Figure 40). Many consider that rock face work imparts the feeling of natural stone, the ruggedness of granite, and a rough and rustic beauty. Tool marks are considered undesirable in rock face work, but these often can be removed later by spalling the granite with an acetylene torch.

The first practical hand-held pneumatic hammer (weighing about fifteen pounds) was designed and patented (1885, no. 323,053) by James S. McCoy of Brooklyn, New York, (Figure 41) based on a smaller dental tool designed by Samuel W. Dennis and patented by him in 1878 (no. 205,169). The hammer operated on 40 psi compressed air that was alternately directed to the back and front of a piston by a transverse annular valve and achieved several thousand strokes per minute. The pneumatic hammer piston impacted a removable tool (or bit) that was held in a spring-retracted tool holder. The pneumatic hammer produced an almost continuous sequence of impacts, allowing a rapid removal of a large quantity of granite during roughing out and producing a very smooth granite surface during finishing. McCoy patented a number of improvements as he experimented with different designs—testimony to the difficulty in designing a really practical pneumatic hammer.

The big breakthrough in pneumatic hammers was the valve-less design, which was first patented by Herman Kotten of New York City in 1898 (patent no. 605,486) but probably invented earlier around 1883 by Thomas Dallett of Philadelphia, Pennsylvania, who never patented his designs. Dallett protected his market by continuous design improvements and by a solid reputation for high quality. Later patents by Samuel Oldham of Philadelphia, Pennsylvania (1898, no. 609,162), and William Holden of Barre, Vermont (1902, no. 711,859), claimed various improvements. The valve-less pneumatic hammer design

resulted in a highly reliable tool with only one moving part—the piston (Figure 42). An elaborate, and usually patented, system of ducts and ports in both the piston and the cylinder wall was employed to alternately direct the compressed air to the front and back of the piston. As it moved, the piston itself opened and closed the input and exhaust air ports to drive the piston back and forth; the movement of the piston itself acted as a valve. The front of the piston narrowed into a neck-like hammer, which extended into an airtight bushing. The front of the bushing accepted the tool shank, which was struck by the piston hammer from two to four thousand times per minute. The manufacturers of pneumatic hammers made many claims—longest wearing, smoothest running, quickest action, least friction, most sparing use of compressed air, and best control of the force of the hammer blow. Each of the major manufacturers (Dallett, Kotten, Oldham, and Trow & Holden) seemed to have had its loyal following of users. In the early 1900s, these small pneumatic hammers cost about \$200 each.

Usually, the stonemason had three sizes of pneumatic hammers: large (1-inch-diameter piston) for initial roughing out, large raised letters, and heavy carving; medium ( $\frac{3}{4}$ -inch-diameter piston); and small ( $\frac{1}{2}$ -inch-diameter piston) for fine work such as sunk letters and tracing and for carving and finish work (Figures 43 and 44). The pneumatic hammer had many different tool bits that performed functions similar to the hand tools.

In fact, some manufacturers offered a detachable striking cap that fitted over the shank of a pneumatic hammer tool bit so that it could be struck with a hand hammer. The point bit was used to rough out stone and knock off high places. The ripper bit was used for fast removal of stone in hard-to-reach places. The cape chisel bit was used for crisping lines, joining corners, detailing, or splitting. The four-point tooth chisel bit was used for fast, aggressive roughing out and the nine-point tooth chisel bit was used after the four-point to make a more uniform surface. The double-blade chisel bit might be used after the four- or nine-point tooth chisel to smooth the surface and take off high points. The three-blade bush chisel

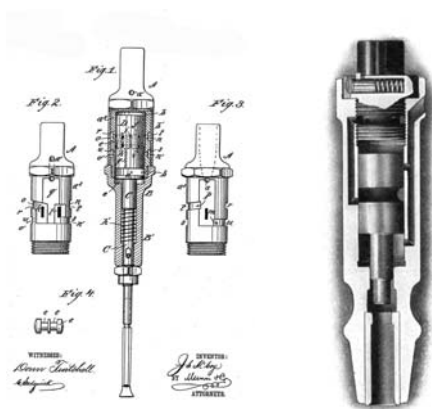


Figure 41 (above, left). 1885 McCoy patent for the first practical hand-held pneumatic hammer, arguably the most important granite industry patent. The piston (D) is shown in Fig. 1 and the valve in Fig. 4.

Figure 42 (above, right). Cross-section view of a valve-less pneumatic hammer. Note the grooved piston and the cylinder wall air ports that route the air alternately to the front and back of the piston without the need of a valve.





bit, smoother than the double blade, leaves an axed or brushed surface. The bush chisel bit, a finishing tool, was used to close the grain. The criss-cross chisel bit might have been used after the nine-point or three-blade chisel and leaves a unique cross-hatched finish. The cup chisel bit, a bushing tool, closed the surface and leaves a unique texture (Figure 45).

## Grinding

The horizontal grinder was a contour grinder designed especially for curved surfaces such as serpentine, oval or beveled tops. It used a ten- to twelve-inch diameter cylinder-shaped Carborundum wheel with a horizontal arbor. The wheel moved over the top of the stone with the curved side of the wheel doing the grinding. The stone was placed on a hydraulically operated car on rails that moved the stone under the Carborundum wheel; the wheel arbor was stationary. The height of the car was determined by following an iron template to produce the desired contour. There were a number of standard template designs for serpentine, oval and beveled tops. If a customer wanted a non-standard contour, a stonecutter was needed to cut

this by hand, guided by a draftsman's drawing.

The molding grinder was used to cut scotias, rabbets, moldings, and the like. The Carborundum wheels varied in size, for example 1/2 inch wide by 24 inch diameter or 2 inch wide by 24 inch diameter. The shape of the cutting surface had a shape that matched the shape to be cut. For planing, a wide wheel was used—for example 6 inch wide by 24 inch diameter. The grinding wheel was mounted on a head whose height was adjusted by the operator. The granite block moved back and forth under the grinding head on a car driven by a linear gear. The length of travel was set by the operator according to the size of the stone. Hand-held Carborundum disc grinders were also used for hard to reach spots and for final touch up.

The vertical grinder was specially designed to grind the straight edges of mausoleum roofs or side stones up to twelve to fourteen feet square. The grinder had a vertically oriented, five-foot diameter iron wheel (with horizontal arbor) faced with Carborundum bricks. The stone was brought in on rollers and wedged into place. The face of the grinding wheel moved over the side of the stone and had a thirty-foot traverse.

## Lettering and Shape Carving

Lettering could be cut by a stonecutter but was usually done by a granite worker who specialized in letter cutting, especially when raised letters were needed. There are four basic types of hand cut lettering; V-sunk (Figure 40) or round sunk; round or square raised; raised rustic (e.g., letters formed by vines or branches); and frosted or polished with outline (see figure in sidebar, page 134). For V-sunk lettering, the letters were cut into a hammered or polished flat surface producing the V-shaped grooves that formed the letters. The best V-sunk work has deep cuts and sharp well-defined edges and bottom. For raised lettering, all the stone on the surface around the letters was cut away leaving the raised letters projecting above the surface. Great care had to be taken to avoid chipping off a piece of the raised letters. The best raised work had a uniform half round profile for the round raised letters and clean sharp edges for the square raised letters.

In the early days of stone lettering, a stonecutter simply cut freehand using a cutter's hand hammer and lettering chisels of various widths, following a mental image of the lettering content, style and layout. Early gravestones include examples where the stonecutter did not plan ahead and ran out of space, having then to use an



Figure 43 (left). Four sizes of valve-less pneumatic hammers for various granite cutting and carving jobs.

Figure 44 (below, left). A granite carver using a pneumatic hammer with a chisel bit.

Figure 45 (below, right). Three pneumatic hammer bits: Nine-tooth chisel, Ripper, and Bush Chisel.



TROW & HOLDEN CO. BARRETT					
<b>TOOTH CHISEL</b>					
Size Stock	Size Shank	Number of Teeth	Price each in Stock	Price each in Previous Price Sheet	
5/8 in.	1/2 in.	4 or 9	\$ .25	\$ .27	
5/8 "	5/8 "	4 or 9	.25	.27	
3/4 "	1/2 "	4, 9 or 16	.30	.33	
3/4 "	5/8 "	4, 9 or 16	.30	.33	
<b>RIPPER</b>					
Size Stock	Size Shank	Size of Cutting Surface	Price each in Stock	Price each in Previous Price Sheet	
1/2 in.	1/2 in.	1/4 in. x 1 in.	\$ .20	\$ .22	
5/8 "	1/2 "	1/4 " x 1 1/4 "	.25	.28	
5/8 "	5/8 "	1/4 " x 1 1/4 "	.25	.28	
<b>BUSH CHISEL</b>					
No.	Opening for Stone	Number of Blades	Price	Price in Previous Price Sheet	
No. 1	3/4 in.	4 to 14	\$2.75	\$ .85	
2	5/8 "	4 to 12	2.50	.75	
3	1/2 "	3 to 10	2.25	.65	
4	3/8 "	3 to 7	2.00	.50	
5	5/16 "	3 to 6	1.75	.40	
6	1/4 "	2 to 5	1.50	.30	



abbreviation or reduced-size letters. More careful workers might trace a design on the stone before cutting, perhaps using a straight edge and lettering block. It soon became clear that much better results were achieved when a draftsman created a full-sized detail drawing of the lettering. Usually, this drawing was shown to the customer who signed it, verifying that he was satisfied and that there were no misspellings or other mistakes. The stone letterer usually owned several dozen  $\frac{1}{2}$ -inch lettering chisels since there were always some being sharpened. Also, he had perhaps a dozen  $\frac{1}{8}$ -inch to  $\frac{3}{8}$ -inch chisels to cut inside the letters (for example A, B, P, R) and narrow places on the outside. For raised letters, he would have a dozen or so  $\frac{5}{8}$ -inch points to work down the background. For the background, some raised letter carvers preferred using a sequence of roughers: a  $\frac{1}{2}$ -inch four-point chisel, a 1-inch double-row toothed chisel, a 1-inch single-row toothed chisel, a 1-inch double row plain chisel, a 1-inch single row plain chisel, and a small bush chisel, of which they would own several of each. Initially these would have been hand tools, but later these would all have been adapted as bits for the pneumatic hammer (Figure 46).

Sandblasting was used as early as 1875 by Sheldon and Slason of West Rutland, Vermont, to cut letters on Civil War gravestones. Chilled iron shields or stencils were used to cut both sunk and raised lettering. Sandblasting was introduced to the granite industry in a major way around 1915 and revolutionized letter cutting and shape carving. Stones to be lettered were put on sandblast skids and wheeled into a stencil cutting room on a hydraulic lift truck. The typical steps in sandblast carving are: creation of the design; drafting of a full-size detail drawing; cementing a rubber stencil onto the stone (rubber mallets and rollers were used to insure that the stencil adhered uniformly to the stone); transferring the design from the detail drawing to the stencil; cutting the stencil with a stencil cutting knife; and sandblasting (blowing) with silicon carbide. Some stencil cutters did both stencil cutting and sandblasting. In 1925, lettering systems were introduced that provided templates for letters of different sizes and fonts (Figure 47). Stencil-cutting machines that could cut letters of different sizes and fonts were introduced in 1968. Sandblast letters do not have as sharp and well-defined edges as hand-cut letters and the bottoms are a more rounded U-shape. Although the sandblast edges can be sharpened with a small hand-held grinding wheel, the practiced eye can still distinguish the two.

Shape carving is three-dimensional ornamentation such as flowers, fruit, leaves, vines, and religious sym-

bols. The best of shape carving takes great skill and long training. For hand shape carving, the tools used are very much the same as those for bas-relief and full round carving. For sandblast shape carving, the stone was blown with fine steel shot abrasive in two or more passes, at each pass cementing on some parts of the stencil that had been removed for the initial sandblasting and cutting additional fine lines in the stencils. The final finishing pass was done with silicon carbide. As with lettering, systems were introduced for shape carving that provided templates for the most common designs of flowers, fruit, vines, religious symbols, and such (Figure 48).

When a stone was ready for sandblasting, it was moved on a sandblast skid into an illuminated steel blowing, or sandblasting, room through a large door at one end of the room (Figure 49). Operator access for the sandblast hose and nozzle was via a blasting curtain and viewing was provided by a window above the curtain. A blast generator blew aluminum oxide abrasive at high velocity and pressure (100 psi) through a sandblast nozzle. Nozzle materials have progressed from hardened iron to ceramic to tungsten carbide to Diamonite (a sapphire-like material) to boron carbide, which is the longest lasting material. The abrasive would cut only the stone surface not covered by the stencil. The sandblast curtain allowed access while at the same time preventing the airborne granite and abrasive dust from leaving the blowing room. The used abrasive fell through a floor grating into a pit beneath and was re-circulated by a sandblast abrasive elevator that cleaned, elevated and stored the abrasive for reuse. Some recent sandblast outfits have "automated curtains" in which the nozzle is moved under computer control and can carry out most or all of the sandblasting without operator intervention. The need to add at least the date of death to an already erected monument has led to the design of cemetery sandblast units that include a portable air compressor, portable sandblast generator, and cemetery lettering sandblast curtain (Figure 50).

## Sculpting and Modeling

The creation of a stone carving normally involved three steps: the designer's drawing, a plaster model, and the final execution in stone. The designer, artist, or architect provided the original conception in the form of a drawing or blueprint. A sculptor then gave the conception a three-dimensional representation in the form of a model (Figure 51). Finally, the carver, using the model as a guide executed the ornamentation, bas relief,



LETTERING



©2013 The Early American Industries Association.  
May not be reprinted without permission.  
www.earlyamericanindustries.org



Number	Size Stock	Size Shank	Width Blade	Length
1014	3/4 in.	3/4 in.	3/4 in.	8 1/2 in.
1016	1 1/2 in.	3/4 in.	5/8 in.	9 in.
1017	1 1/2 in.	1 1/2 in.	5/8 in.	10 in.
1018	1 1/2 in.	1 1/2 in.	5/8 in.	9 in.
1019	1 1/2 in.	1 1/2 in.	5/8 in.	11 in.
1020	3/4 in.	1 1/2 in.	3/4 in.	9 in.
1022	3/4 in.	3/4 in.	3/4 in.	9 in.
1026	3/4 in.	3/4 in.	3/4 in.	9 in.

POINTS



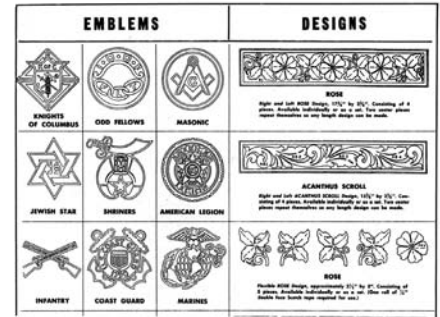
Number	Size Stock	Size Shank	Length
1028	3/4 in.	3/4 in.	9 in.
1030	1 1/2 in.	3/4 in.	9 in.
1032	1 1/2 in.	1 1/2 in.	9 1/2 in.
1034	3/4 in.	1 1/2 in.	9 1/2 in.
1036	3/4 in.	3/4 in.	9 1/2 in.



Better Letters



PACERITE will save you hundreds of dollars a year. It is an invention by which you can lay out and draw a monument inscription in a few minutes, with absolute correctness and uniformity of lettering, and perfect spacing. The work is equal to that of the best designer, is ten times as fast, and anyone can do it. SPACERITE has no hours, no wages, no cost but the first cost, no upkeep, and it lasts forever. You can make as many copies as you want — for your customer, for file, for transfer to the stone or sand-blast.



or full-round statue. Sometimes a maquette, half size or less, was produced and the carver had to scale up in order to carve the full-size stone sculpture. Often a small plaster model was created as an approval model before the full-scale or maquette model was sculpted. For large commissions, each step may have been executed by a different person. For small or medium-size projects, often two or more steps were executed by the same person. Some pre-1940 noted Barre, Vermont, sculptors were Carlo Abatti, Angelo Ambrosini, John Comi, Elia Corti, William Corti, Enrico Mori, Samuel Novelli, Augusto Sanguinetti, Lambruno Scrzanini, and Gino Tosi. The 1899 Robert Burns monument in Barre, Vermont, was sculpted by Massey Rhind and carved by Samuel Novelli, and the pedestal bas-relief was designed by James B. King and carved by Elia Corti. It is one of the world's outstanding examples of full-round and bas-relief granite carving (Figures 52 and 53).

Referring to the design drawing, the sculptor would create a three-dimensional clay model using a variety of clay sculpting tools. The clay would sit on a sculptor's turntable illuminated by a portable, adjustable-height lamp. At this point, the customer and/or designer was shown the model (or a photograph of the model) and would often suggest changes to the model before carving (Figure 54). From the clay model, a plaster mold would be produced. Thin pieces of overlapping tin were stuck in two lines into opposite sides of the wet clay model and projected about six inches above the clay. The clay model was then covered with a thin mixture of colored plaster of Paris, making sure the plaster penetrated into every fold and crevice. As soon as this layer had hardened, several additional layers of thicker plaster were added until a thickness of about six inches was achieved. After this had dried and set, about twenty-four hours, the two halves of the plaster mold, separated by the tin pieces, were removed. Any remaining parts of the clay model that still adhered to the mold pieces were removed, usually destroying the clay model in the process. The mold pieces were washed out, dried, and a special grease was applied to the inner surface to prevent sticking. The mold was then reassembled and used to create the final and more durable plaster model. First, a thin plaster was poured into the mold, which was turned in various directions to insure the plas-



Figure 46 (top, left). Two pneumatic hammer bits: lettering chisel and points.

Figure 47 (top, middle). Spacerite lettering system. The system included templates for many different letter sizes and fonts.

Figure 48 (top, right). System for emblems and designs. The system included templates for the most commonly used emblems and ornamental designs.

Figure 49 (above). A complete sandblast outfit—from left to right can be seen: the sandblast generator, the sandblast curtain and window, the blowing room, and the dust collector.

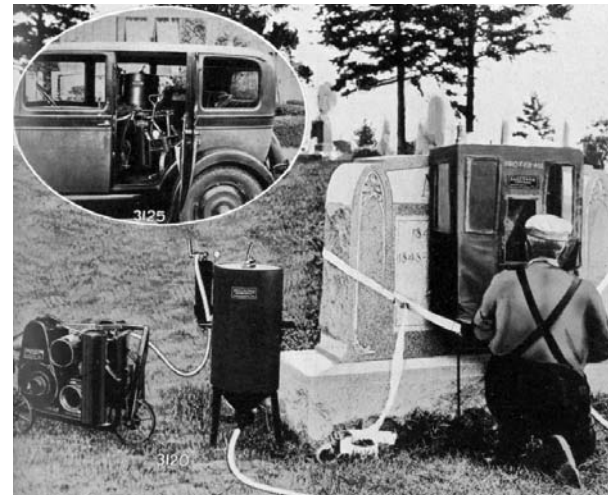


Figure 50. Cemetery sandblast outfit. From left to right: portable air compressor, sandblast generator with hose and nozzle, and sandblast curtain. The inset shows all this equipment packed into the back of the sandblaster's sedan.



Figure 51 (left). Plaster model of St. John, the evangelist. The model was sculpted by Orazio Marcelli and granite bas-relief carved by Angelo Bardelli in 1959 at the Comolli Granite Co., Barre, Vermont.

Figure 52 (above, center). Robert Burns statue in Barre, Vermont. The poet is depicted as a plowman returning from a day in the fields.

Figure 53 (above, right). Robert Burns statue base with four bas-relief panels depicting scenes from Burns's poems. On the left, "To A Mountain Daisy" and on the right "The Cotter's Saturday Night."

Figure 54 (right). Clay model of the Madonna with written requests for changes: younger face, tilt head to front, more definite bust line, hands more feminine, longer fingers, slim clothing below the waist, etc. These are changes that can be easily made to a clay model.

ter filled every detail in the mold surface. After this layer had set, several additional layers of thicker plaster were built up to provide strength for the model but leaving a hollow center. Finally, after the plaster had set, the mold was removed, breaking it if necessary. Any colored bits of plaster from the mold still adhering to the white model were carefully removed.

Various materials, liquid latex or liquid vinyl, are now available that can be painted on the clay model to form a mold. About a dozen quick-trying coats of latex are painted onto the model and then a plaster mother mold is poured around the latex-covered clay model. The mother mold is removed and the latex is removed from the clay model and put into the mother mold. Finally, plaster is poured into the latex-coated mother mold to create the plaster model. The vinyl mold-making material is painted on and after baking is stiff enough to use as a mold without the need for a mother mold.

### Carving

The carver had to understand and carry out the intentions of the designer and sculptor. However, the surface treatment and expressive details belonged to the carver. The carver's responsibility was very similar to the musician's in interpreting the intent of the composer. The process of sculpting in clay and carving in stone is very

different. Sculpting is a process of addition (putting on) whereas carving is a process of reduction or revealing (taking away). What a sculptor takes off can be put back on. What a carver takes off can't be put back. Although this is not entirely true since many carvers have their own specially formulated filling compounds that can be used in certain situations. Carving involves reduction and risk and requires great patience.

Stone workers were classed in three levels of increasing skill: stonecutters, ornamental carvers, and figure carvers. A student, on his way to achieving master carver status, usually passed through these three levels. Each level brought increasing respect and pay. Stonecutters did the rough shaping of stone—into flat or curved surfaces that may be chiseled, hammered, rock faced or polished. The stonecutter may have been aided by a variety of machines such as surfacers and polishers. Carvers almost exclusively used hand-held tools—some powered by compressed air. Carvers who did primarily artistic work were more highly respected than those who did primarily repetitive commercial work. The master carver went beyond technical skill to a true creative and artistic level. In final finishing, the most skilled of the master carvers gave the stone movement, grace, realism, power and life—even tenderness and emotion. He did this through a combination of shadow—chiaroscuro, contrast, texture and color.





The master carver typically owned and used a few hundred hand tools. These included pitching tools, chisels, gouges, files, rasps, wood mallets, steel hammers, drills, pointing machines, calipers, carpenters' squares, level, plumb bobs, rulers, tape measures, straight edges, scale triangles, scribes, pencils, sandpaper, sandpaper blocks, Carborundum stones, carvers' turntable, lamps on an adjustable stands, and safety glasses. The carver also used a small pneumatic carving hammer—a 1/2-inch bit shank and a 3/4-inch or 1-inch piston diameter (see Figure 44)—with: a point or roughing chisel for heavy removal and rough usage; a carving chisel for general carving, sculpting, and lettering; a cleaning-up chisel for finishing that scrapes and closes the grain; and a carver's drill that drills small-sized, round holes for detail carving (Figure 55). Often, the carver had a favorite dozen or so tools which he uses most of the time.



Figure 55 (above). A modern set of carver's tools. These have changed very little over more than a century, the biggest change being the carbide tip that lasts an order of magnitude longer than an ordinary steel tip.

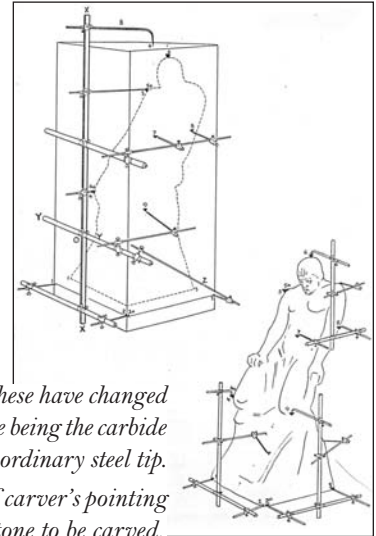


Figure 56 (right). A drawing showing placement of carver's pointing machines on a full-size plaster model and on the stone to be carved.

Often, the carver had a favorite dozen or so tools which he uses most of the time. After selecting a granite block, holes were drilled around the statue outline, and the excess was broken off with a hammer and chisel. Rough shaping was commenced with a hammer and chisel. A carver's apprentice may have done the initial roughing out. Plane surfaces were cut on the three-dimension figure using a pneumatic hammer with a point, a ripper, a four-point tooth chisel, or bush chisel. The pointing machine was used to transfer distances and relative locations from a plaster model to the stone as it was being roughed out, insuring that the sculpture closely followed the model. The pointing machine consisted of a main vertical rod with several horizontal rods connected to the main rod by setscrew-tightened clamps (Figure 56). Small-diameter pointed rods were connected to the vertical and horizontal rods also by setscrew-tightened clamps. The pointing machine was first adjusted so that its points were resting on reference points on the plaster model. The sculptor would have previously embedded reference points (metal pins) in the model for use by the pointing machine. Then the machine was moved to the stone where the points established the same reference locations. The machine was usually moved back and forth a number of times as the roughing out progresses, each time adjusting the number and location of the points. For a large sculpture, two or more machines would have been used. A typical pointing machine was 28 inches high by 20 inches wide but could be custom-ordered in larger and smaller sizes.

Once the stone was roughed out close to the finished surface, the pneumatic carving hammer with a nine-point tooth chisel, double-blade chisel, three-blade chisel, bush chisel, criss-cross chisel, or cup chisel was used to bring the stone almost down to the final surface. The carver would go over the statue from head to toe many times with a fine pneumatic chisel—each time adding more detail to face, hands, feet and clothing. Usually, the final detailing and smoothing was done by hand with finishing chisels and gouges, fine drills, files, rasps, and sandpaper.

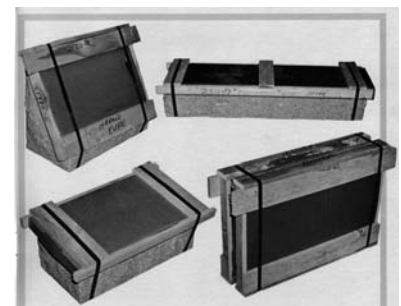


Figure 57 (above, top). Crated die, base and markers.

Figure 58 (above). Erecting granite for the Cleveland City Hall in 1914. Woodbury Gray Granite from the Woodbury Granite Co. was used. Note the flat car with crated granite on the left and piles of crated granite on the right.

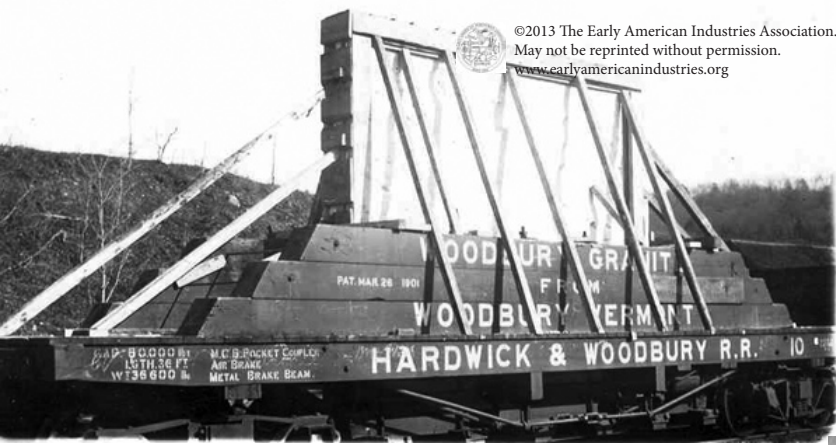


Figure 59 (left). Hardwick & Woodbury Railroad well car transporting a large piece of granite, probably a mausoleum roof stone. The well opening measured 4 feet by 20 feet.

Figure 60 (below). Truck being loaded by boom derrick from a stone yard of crated monuments at Barre, Vermont.

## Washing and Boxing

The washing and boxing stand was typically constructed of 4- by 4-inch wooden beams. The stone was set on the stand and washed with muriatic acid to clean off steel shot fragments if it still had sawn surfaces exposed. Otherwise, the stone was washed with a weaker cleaning solution. The sandblast stencil was removed, having been left on to this point to protect the polished face from scratching, and the stencil cement was cleaned off. The acid was stored in a five to ten gallon stoppered glass jug that was kept in a tilting acid stand. The acid was decanted into gallon acid jugs by tilting the large jug. The gallon jug had a six- to eight-inch hose in its mouth so the jug wouldn't break against the stone. First the stone was wet down. Then acid was poured on from the gallon jugs and scrubbed in with an ordinary scrub brush. The washers used rubber gloves and some also wore rubber aprons. For a stained area where abrasive shot had lain for a period, extra acid would be used and additional scrubbing done. Finally, after it had set a short while, the acid was rinsed off with water.

The washing and boxing stand had a small boxing crane to lift the stone onto a crate bottom. The crate bottom had a slot so that the lifting rope could be easily pulled out. The top of the crate was put on, the corners put on and the whole secured with steel straps tightened with boxing tongs. Recently, the increased cost of lumber has led to a simplification of crate designs requiring less wood (Figure 57). The crated stone was then placed on a transfer car and taken to the finished granite storage area. This was the shipping area from which crated stones were sent to the customer. Crated standard-size monuments were also kept in the storage area to fill rush orders. These were produced during the winter when business was slack.

## Transport and Setting

Granite for long-distance shipment was often consolidated into a single railroad flatcar load of both slabs and finished work for multiple custom-



ers—often 120,000 pounds on one flatcar. The stones were braced and wedged between hardwood car stakes so they wouldn't shift during transport. An expert car loader could so perfectly balance a load that he could stand on top of a fully loaded car and make it sway on its springs (Figure 58). The services of a well car might be needed to transport extra large stones. The well car had an open center or well in which a mausoleum roof stone or a large column capital could be carried just a few inches above the rail bed so they would fit under bridges and through tunnels (Figure 59). By the 1950s, trucks were doing most of the granite hauling (Figure 60). In some cases, the truck would take the stone to the local depot for rail shipment.

## Author

EAIA member Paul Wood is a retired electrical engineer, who worked his entire career in the computer industry. He is interested in the tools, implements and machinery of the granite industry and of nineteenth- and early-twentieth-century farming in New England.





The Early American Industries Association

President: Donald D. Rosebrook
Executive Director: Elton W. Hall

THE PURPOSE of the Association is to encourage the study of and better understanding of early American industries in the home, in the shop, on the farm, and on the sea; also to discover, identify, classify, preserve and exhibit obsolete tools, implements and mechanical devices which were used in early America.

MEMBERSHIP in the EAIA is open to any person or organization sharing its interests and purposes. For membership information, write to Elton W. Hall, Executive Director, 167 Bakerville Road, South Dartmouth, MA 02748 or e-mail: eaia@comcast.net.

The Chronicle

Editor: Patty MacLeish

Editorial Board

- Katherine Boardman, John Carter, Jay Gaynor, Raymond V. Giordano, Rabbit Goody, Charles F. Hummel, Walter Jacob, Johanna M. Lewis, Ph.D, Michael H. Lewis, Dan Reibel, Bill Robertson, Jack Whelan, Frank White

The Chronicle welcomes contributions from anyone interested in our purpose. Submit articles to: Patty MacLeish, Editor, 31 Walnut Street, Newport, RI 02840. Telephone: (401) 846-7542; Fax: (401) 846-6675; E-mail: pmacluish@verizon.net. We prefer articles to be submitted on disk or electronically. Please submit in any commonly used word processing program. If typed, please double space.

The Chronicle of the Early American Industries Association, Inc.

Volume 60, No. 1

March 2007

Contents

Codes and Symbols of European Tools, Part 1 by Laurent Adamowicz 1
Tools and Machinery of the Granite Industry, Part IV by Paul Wood 10
Ohio's Sandstone: Once the Source of the World's Finest Grinding Stones by Dana Martin Batory 36
Departments
Stanley Tools by Walter W. Jacob Justus Traut's Improved Miter Box 33
Book Review: Handy Book a Must-Have for Stanley Collectors The Stanley Little Big Book: A Comprehensive Pocket Price Guide for Planes Reviewed by Paul Van Pernis 42
Plane Chatter by J. M. Whelan Early Totes 43

Covers

Front: Details of three tools showing various symbols—stars, crosses, hearts, fish bones, and the letters "IOS"—commonly found on European tools. The tools pictured are (left to right): a French, eighteenth-century osier-splitting tool combined with a bread stamp, engraved with fish bone pattern and a cross (length: 3 inches); a five-branch star inserted in a circle inside a heart, engraved on the plate of an eighteenth-century eucharistic bread iron dated 1788; and the letters "IOS" hidden under the iron and wedge of a wooden plane from the Savoie region in the Alps, dated 1744. Laurent Adamowicz writes about these codes and symbols beginning on page 1.

Back: A 1905 photograph of a block and tackle assist for hauling a large granite block by wagon in Sharon, Vermont. The granite block was destined for the Joseph Smith Monument. Paul Wood concludes his series on the tools and machinery of the granite industry beginning on page 10.

The Chronicle of the Early American Industries Association, Inc. (ISSN 0012-8147) is published quarterly by the Early American Industries Association, Inc. Elton W. Hall, Treasurer, 167 Bakerville Road, South Dartmouth, MA 02748. POSTMASTER: Send address changes to: The Chronicle of the Early American Industries Association, Inc. c/o Elton W. Hall, Treasurer, 167 Bakerville Road, South Dartmouth, MA 02748. USPO Publication Number 560-620. Periodical postage paid at New Bedford, MA, and at additional mailing offices. ©2006 The Early American Industries Association. The Chronicle is available on microfilm from: ProQuest, 300 Zeeb Road, Ann Arbor, MI 48106. Articles appearing The Chronicle are abstracted and indexed in Historical Abstracts and America: History And Life. Design: Patty MacLeish, Ideas into Print, 31 Walnut Street, Newport, RI 02840. Printed by Cayuga Press, 1650 Hanshaw Road, Ithaca, NY 14850.



# Tools and Machinery of the Granite Industry, Part IV

by Paul Wood

This article is the last in a series of four on the tools and machinery of granite working. Part I (*The Chronicle* 59, no. 2) described granite as a material, an industry, and a product and began the description of the granite quarrying process. Part II (*The Chronicle* 59, no. 3) completed the account of granite quarrying. Part III (*The Chronicle* 59, no. 4) concerned the most common finishing operations. This final article continues the description of finishing operations, focusing on some of the more exotic but nevertheless important finishing steps and their associated tools and machines including turning, flute cutting, boring, corrugating, lapping and etching. In addition, this article will describe the processing of waste granite including paving-block cutting, paving, and crushing. Finally, the article will conclude with a discussion of power sources, the various finishing job categories, labor unions, and safety and health issues.

## Turning

The granite-cutting lathe was similar to a wood- or metal-working lathe, but in its largest size was much larger and heavier than the wood or metal lathe (Figure 1).

The lathe was very important for architectural and monumental granite in the finishing of columns, balusters, urns, vases, and spheres. Like a common lathe, the granite lathe had a headstock and tailstock between which the stone to be turned was supported and rotated. The headstock was driven by a variable-speed pulley cone or set of gears, and the tailstock was movable along the ways to accommodate stones of different lengths up to thirty-five or so feet. The Woodbury Granite Co. of Hardwick, Vermont, had a lathe that could turn columns up to thirty-five feet long and forty-eight inches in diameter. A slower speed was used for the initial rough turning. Before wire saws were available to cut rolls into an octagonal cross section, the stone block was hand pointed by stonecutters to a rough, circular cross section prior to turning in the lathe. The pointed surface was taken to within 1 to 1½ inches of the final surface. A tool carriage was screw-driven along the entire length of the lathe and held a freely turning, 8-inch diameter cutting disc. The disc was tempered steel with its working perimeter beveled to a sharp edge (Figure 2). As the tool carriage moved along the length of the lathe, the disc was forced into the stone, crushing and removing granite rather than cutting as with a wood

or metal lathe. For each pass of the tool carriage, the disc was moved incrementally inward until the desired column diameter was achieved. Sometimes a driven Carborundum wheel was mounted on the tool carriage for the final cut. Today, instead of the cutting disc, a plunge saw mounted on the lathe tool carriage is used, which makes a series of shallow cuts close to the final surface. The material between the cuts is broken out and a diamond saw mounted on the tool carriage is then used to cut the final surface.

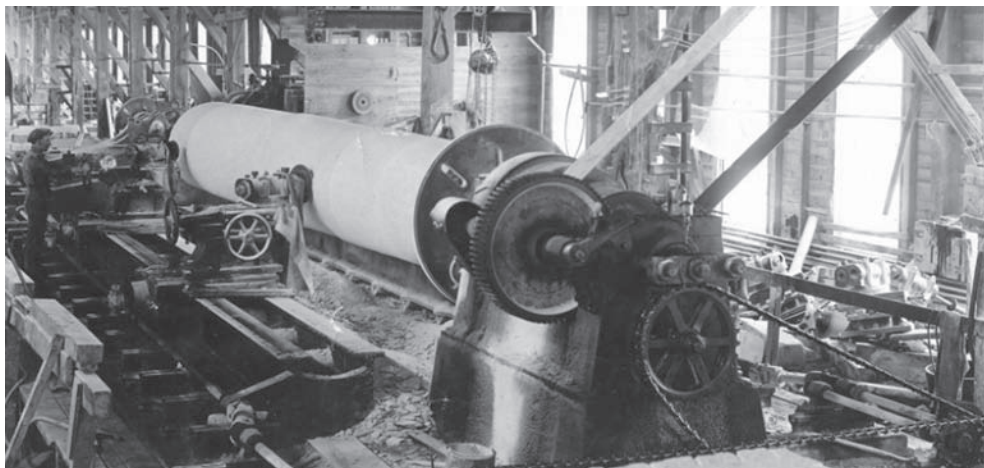


Figure 1 (above). Cutting lathe at the Woodbury Granite Co. The lathe is electric-motor driven via flat belt and speed-reduction gears. Note tool carriage with cutting disc.

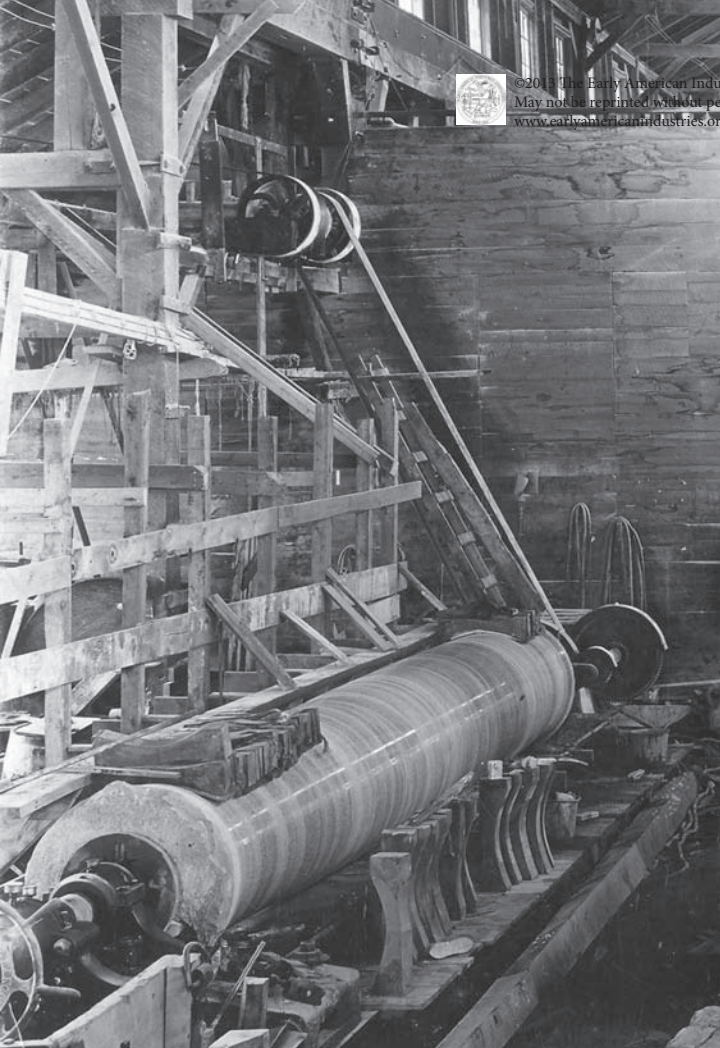
Figure 2 (left). The lathe-cutting disc ranged in size from 8 to 18 inches in diameter.

LATHE DISC



Made of Peerless Extra Steel, carried in stock in two sizes:  
 16 by 3-4 in., and 14 by 5-8 in.; other sizes to order.  
 Price, not finished, per lb. . . . . \$ .14  
 Finishing, each . . . . . \$1.25 to \$2.00  
 In ordering finished discs, give size of arbor.



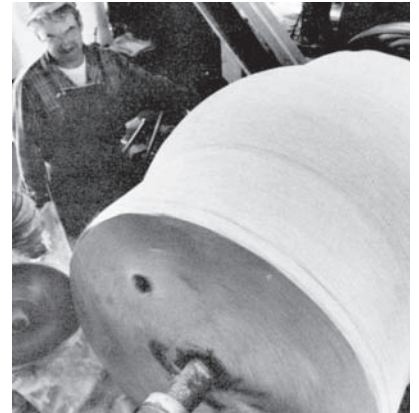


*Figure 3 (left). Polishing lathe at the Woodbury Granite Co. Note the cast iron grinding blocks on top of the rotating column and extra blocks stored in front.*



*Figure 4 (right). Turning a vase at Gearson & Lane Co., Barre, Vermont. The granite worker is using calipers to insure exact dimensions. Gearson & Lane was Barre's primary manufacturer of lathes and producer of turned granite work.*

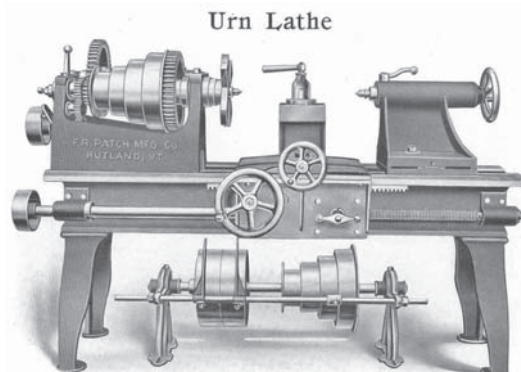
*Figure 5 (below). An early stage of turning a sphere.*



circumference and were curved according to the desired finished column surface curvature. The blocks were pushed by the rotation against a plank behind the lathe and were thus held in position. First sand and then emery was shoveled up over the grinding blocks by the operator from an abrasive trough under the lathe. The blocks were occasionally pushed a distance of half their width along the column to avoid surface rings. When the grinding was completed, 8-inch wide cast iron polishing blocks (each weighed about a hundred pounds for a 40-inch diameter column and about fifty pounds for a 20-inch diameter column) with felt-covered undersides were substituted for the grinding blocks, and oxide of tin was used as an abrasive. It required a total of from forty to fifty hours to polish a column to a mirror-like surface. The Woodbury Granite Co. had a polishing lathe that could accommodate a stone 25 feet long and 60 inches in diameter.

The grinding lathe was used after the cutting lathe to produce a smooth (but not polished) surface—typically for columns. A long, straight-edged strip of iron was held by weighted rods against the stone, and the operator periodically shoveled abrasive slurry from boxes under the turning stone. Initially, sand was used and later tungsten carbide shot when it became available.

The polishing lathe was similar to the cutting lathe except it was usually smaller and did not require a tool carriage (Figure 3). The head stock was driven by a cone of step pulleys allowing for variable turning speed; polishing was done at a surface speed of 230 to 240 surface-feet per minute. For example, a 12-inch diameter column was turned at about 76 rpm, whereas a 36-inch diameter column was turned at about 25 rpm. Initial grinding was performed by a series of three- to four-inch wide cast iron grinding blocks that rested, tightly spaced, on top of the turning column. The blocks came in contact with about one-quarter of the column



*Figure 6. Urn lathe manufactured by F.R. Patch Mfg. Co., Rutland, Vermont. The pulley shaft shown under the lathe was mounted on the ceiling with its pulley cone directly above that of the lathe.*

Large column lathes were not cheap. In 1919, F.R. Patch Mfg. Co. of Rutland, Vermont, advertised a lathe that could turn a 24-foot long stone with a 66-inch diameter; it cost \$11,200 with \$490 added for each addition foot of length ordered. Another Patch lathe, advertised as a heavy granite lathe, which could turn a 31-foot long by 108-inch diameter stone, cost \$35,700 (excluding motors). The largest granite lathe of which the author is



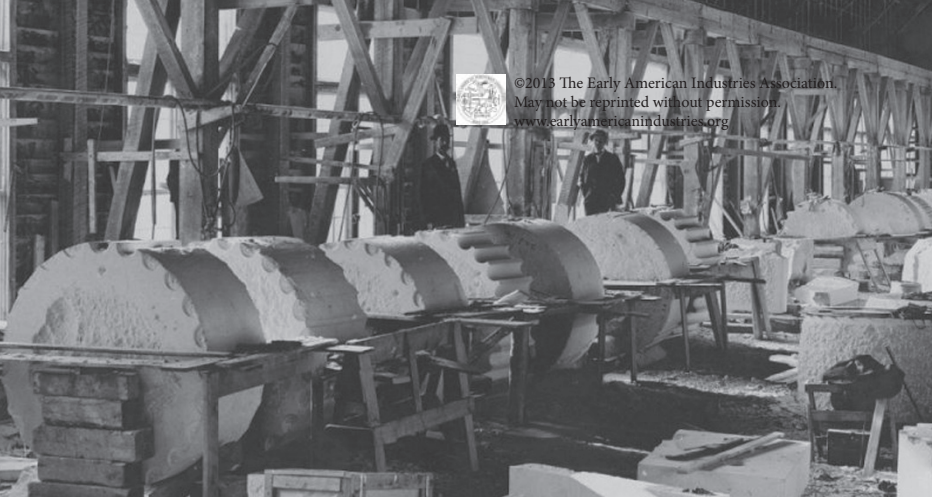


Figure 7 (above). Column sections—probably for Union Station in Washington, D.C.— at various stages of fluting at the E. B. Ellis Granite Co., Northfield, Vermont.

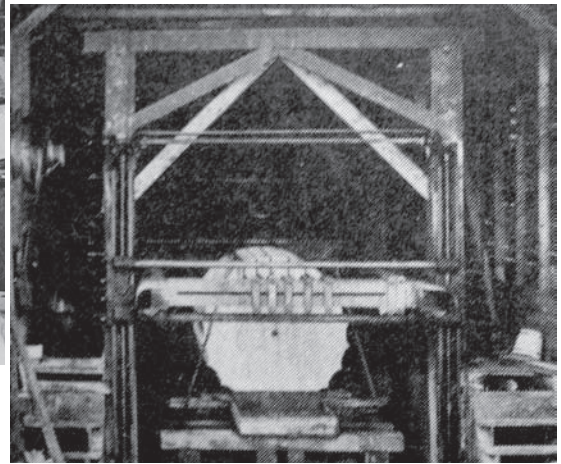


Figure 8 (right). Gang-saw-like fluting machine with five blades in use.

aware was the mammoth \$50,000 lathe at the Bodwell Granite Company of Vinalhaven, Maine, that was used from 1902 to 1904 to turn eight, 54-foot long by 6-foot diameter columns for the Cathedral of Saint John the Divine in New York City. Balusters, urns, vases, and spheres were turned on smaller lathes (Figures 4 and 5). Patch advertised urn lathes that could turn a 16-inch diameter by 2- to 4-foot long stone at a cost of \$945 to \$1,260 (Figure 6).

### Flute Cutting

Many building and monument columns were fluted (Figure 7). That is, long parallel grooves were cut lengthwise into the column. Prior to the availability of flute-cutting machines, flutes had to be cut by hand—an extremely labor-intensive process. One early flute-cutting machine design was used for sectioned columns (i.e., columns made up of a number of stacked two- to three-foot high sections), and looked like a small version of a gang saw (Figure 8). A column section was secured on its side on a saw cart under five or so saw blades, spaced according to the flute separation. Cuts were made to the proper depth and the column was rotated, and more cuts were made until cuts had been made around the entire column circumference. In a second design, the column section was mounted upright on a stand (Figure 9). There were two driven Carborundum grinding wheels that were moved up and down against the column on posts located on opposite sides. The grinding wheel surface had the profile desired for the fluting grooves. With each up and down travel of the grinding wheels, they were incrementally moved in toward the column center until the proper flute depth was reached. The column was then rotated by one flute spacing, and the process repeated until the entire column circumference had been fluted. A third type of fluting machine was de-

signed as an attachment to a stone-cutting lathe and could flute a monolithic column up to the maximum length handled by the lathe (Figure 10). A driven Carborundum grinding wheel, with the proper grinding surface profile, was mounted on the lathe tool carriage. The column was locked into position in the lathe and the Carborundum wheel was moved back and forth the full length of the column, being incrementally moved in toward the column center for each full-length pass until the proper flute depth had been achieved. The column was then rotated in the lathe by one flute spacing and the process repeated until the entire circumference had been fluted.

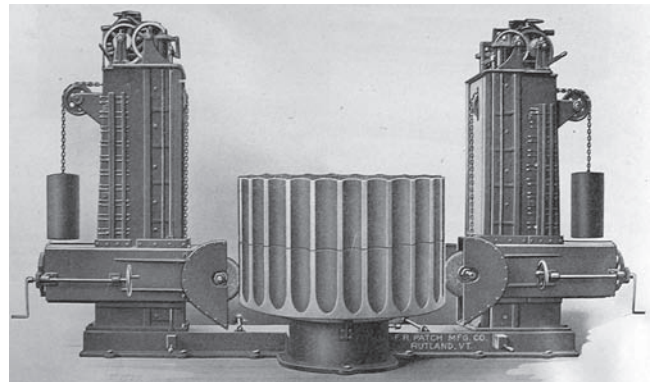


Figure 9 (above). Upright fluting machine manufactured by F.R. Patch Mfg. Co. (1919). Note the driven Carborundum grinding wheels on either side of the column section.

Figure 10 (below). Fluting lathe by F.R. Patch Manufacturing Co., Rutland, Vermont. A driven Carborundum grinding wheel would be mounted on the tool carriage.

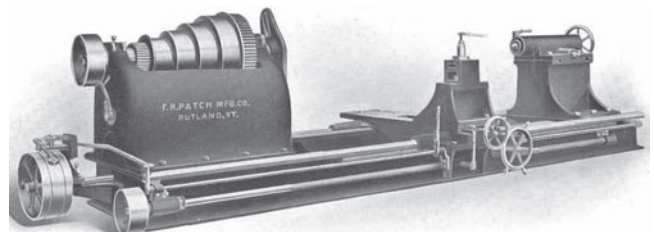






Figure 11 (left). A row of four boring machines at Jones Brothers Co., Barre, Vermont. Not visible are the pits beneath the machines needed to accommodate long columns.

Figure 12 (below). Press roll (55 tons, 32½ feet long) on a cutting lathe at the Wells Lamson Quarry Co., Barre, Vermont.

Figure 13 (above). Discarded chocolate rolls at the Jones Brothers Co. site, Barre, Vermont.



## Boring

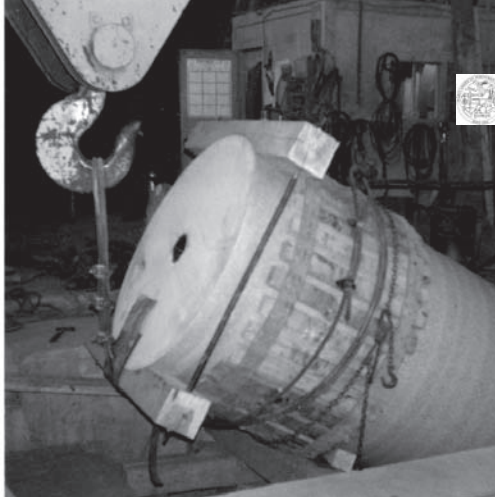
A boring pit, with a flat-belt-driven, vertical-shaft drill, was used to bore arbor holes in press and chocolate rolls (Figure 11). A paper-mill machine used a pair of granite press rolls at the beginning of the paper-making process where the wet pulp was pressed into a sheet and where the superior releasing property of the granite was essential to prevent the wet sheet from sticking to the rolls. At their largest—5 feet in diameter by 40 feet long or about sixty-six tons—press rolls could be massive (Figure 12). In the manufacture of chocolate, beans were ground into a fine slurry using corrugated granite rolls that moved back and forth on a granite bed until the desired degree of fineness was achieved. The finished dimensions of a chocolate roll were 22½ inches long by 11¼ inches in diameter (Figure 13).

The drill bit was a hollow pipe with a notched cutting edge, using the same rectangular notch configuration as used for the gang-saw blades. As with the gang saws, steel shot abrasive was used. The pits were of various depths to accommodate rolls of various lengths. A roll

was set into the pit by an overhead crane (Figure 14). It was bored halfway through and then turned over and the other half was bored. Alignment of the two bores had to be precise. A plumb bob and depth gauge were used to accurately position the roll. The plumb bob was hung from the center of the drill bit and this point was marked on the pit floor. A circle with the diameter of the roll was chalked on the floor with the point as center. The roll was then positioned in this circle and plumbed using the depth gauge to ensure that the distance between the roll's top edge and the drill bit was equal all the way around. Boring was a dusty operation so suction equipment was usually installed for this machine.

## Corrugating

Corrugating machines were needed for the manufacture of chocolate-milling machines. A chocolate-milling machine consisted of a 6-foot long corrugated granite bed with thirteen straight lengthwise end-to-end grooves. Three, 22½-inch long, corrugated chocolate rolls ganged together were driven back and forth through chocolate slurry in the bed by a crank and



©2013 The Early American Industries Association.  
May not be reprinted without permission.  
www.earlyamericanindustries.org

*Figure 14. Lifting a press roll into position in a boring pit at the Wells Lamson Quarry Co., Barre, Vermont. Note the band of two-by-fours wrapped around the roll to protect its surface from damage by the lifting cable.*

pitman rod. Roll corrugations would fit precisely into the bed grooves. (The following description is based on the operation at Jones Brothers, Barre, Vermont.)

The chocolate roll started square. The corners were sawed off to make it octagonal in cross section. It was then cut round on a small cutting lathe. The ends of the rolls were parallel to the hard way so that the cutting on the lathe was done in the easier rift and grain directions. Then, an arbor hole was drilled as described above and a shaft was run through and tightened in place with a hub on either side. Finally, the roll was placed in a roll-corrugating machine, similar to a lathe. The roll was rotated under two wedged-in and lever-weighted, corrugated-edged strips of iron in a Carborundum abrasive slurry. The iron strip's grinding edge had the desired corrugation profile.

A bed-corrugating machine was used to cut the grooves (very much like corrugated metal roofing) in the chocolate mill beds. The bed corrugating machine consisted of an iron rack about 30 inches long and 9 inches wide with thirteen, 1-inch-diameter, heavy-duty pipes that were flattened into oval cross-sections. The weighted rack was driven back and forth across the bed in a Carborundum abrasive slurry with a crank and pitman rod. Periodically, the operator measured the corrugating progress with a template gauge made of galvanized sheet steel. Finally, a corrugation-mating machine drove the newly made chocolate rolls across a newly made bed in a Carborundum-abrasive slurry until the roll ribs exactly fit the bed grooves. Only the roll ribs touched the bed. The rolls and bed were marked with the same number and were meant to be used together.

## Lapping

Today, the aerospace, automotive, electronics, optical, and other industries require precision manufacturing processes involving precise relative positioning of manufacturing equipment. Granite plates are used as the mounting substrate to achieve this precise positioning. Granite plates have exceptional dimensional stability due

to a low coefficient of thermal expansion, making granite plates less susceptible to contour changes due to ambient temperature changes. In addition, the density and high resonant frequency of granite help to isolate equipment mounted on a granite plate from ambient vibrations from many sources in the immediate environment. The transmission of vibrations is a very serious problem for any type of precision manufacturing.

The key objectives in the manufacture of a surface plate or a machine base are to make one or more faces as flat (planar) as possible and to generate other types of critical geometry such as perpendicularity, parallelism, and coplanarity between edges and faces of the surface plate. This is achieved by an alternating series of lapping and measuring steps—using progressively finer grit lapping and more precise measuring. Surface plates have been made in sizes up to 28 feet by 10 feet, and as long as 50 feet for applications as diverse as platforms for rocket motor components to bases for measuring machines for the automotive industry.

The initial step in manufacturing a granite plate from a block is slab sawing to the desired thickness with either diamond wire or very large, diamond-tipped multi-blade saws. The plate is next sawed to the desired length and width with smaller, computer-controlled, diamond-blade or diamond-wire saws. The initial flatness or other geometry is established by surface grinders ranging in capacity from 2 feet wide with a 6-foot stroke, to 12 feet wide with a 23-foot stroke, utilizing diamond composition grinding wheels. After the grinding phase, lapping is begun with powered lapping machines using various abrasives. To achieve the final critical geometry, lapping is done by hand with various types of lapping blocks, custom made for each application and utilizing either diamond or other types of special abrasives in progressively finer grits. Alternately, the surface is cleaned and allowed to return to environmental temperature, after which the flatness and/or other critical geometry is measured with extremely accurate electronic levels, autocollimators, or other precision measuring devices. This data is entered into a computer program to create a displayed contour map of the surface, which is then used to determine where and how much additional material needs to be removed from the measured surface. The process continues in this sequence until finally finished to specification. Achieving the final specified geometry can take anywhere from two to three hours for the smallest of plates or components to many days (and possibly weeks) for very large plates. (The above description is based on the current Rock of Ages manufacturing procedure.)



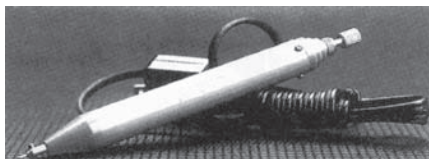


Figure 15. Electric-powered etching tool.

## Etching

A hand-held carbide or diamond-tipped vibrating tool was used to etch illustrations or designs on the polished granite surface of a monument or other stone artwork (Figure 15). Etching is particularly effective on black granite where the tool leaves a white line on a black background—the reverse of a pencil drawing on white paper. The etcher was usually an artist who did free-hand work. Computer-controlled, laser-etching machines are now available that can etch digitally stored portraits or scenes with photographic exactness.

## Paving-Block Cutting

Paving-block cutters were a breed unto themselves, more transient than most granite workers and forced to roam from Maine to Georgia in search of contracts. They were paid by piecework and generally earned more than the average stonecutter, but much of the extra money was eaten up by their forced travels.

Starting with a one- to three-foot long granite block with the easy way (rift) marked, a line of holes was drilled along the rift 8 inches back from the edge using a hand drill and drill hammer. Next, the block was split with wedges and shims placed in the drilled holes, producing an 8-inch thick slab. A cut was then made along the grain (lift) with a line tracer, producing a fracture line a ¼-inch deep along the center of the top of the slab. Next, a hole was drilled in the center of the fracture line. A bull (or opening) wedge was set in the hole and struck with a twenty-pound hammer causing the stone to split along the fracture line (Figure 16). This process was repeated to produce quarter sections and then eighth sections. A line of fracture was now chiseled in each eighth section. The eighth section was turned over and struck two or three heavy blows opposite the line with a six- to sixteen-pound mash hammer which had one rectangular flat face and one sharp peen face or bursting hammer, which had one striking face and one blunt peen face, causing the stone to split along the fracture line (Figure 17). This process was repeated



Figure 19 (left). Paving-block cutter using a reel hammer to trim a paving block over his chipping tub at the Rockport Granite Co, Rockport, Massachusetts.

Figure 20 (below). Belgian- and Boston-pattern paving hammers.

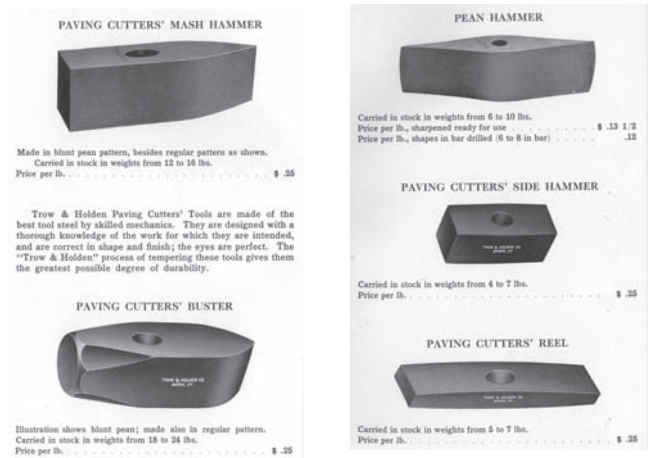


Figure 16 (top). Paving-block cutter's bull (or opening) wedge.

Figure 17 (above, left). Paving-block cutter's mash and busting hammers.

Figure 18 (above, right). Paving-block cutter's peen, side and reel hammers.

on the sixteenth sections to produce the rough paving blocks. Next, each paving block was faced (trimmed and smoothed) with a four- to seven-pound side hammer, which had two, square, flat faces, or reel hammer, which had two, rectangular, flat faces, until the block was symmetrical and correct in dimensions (Figure 18). The chips resulting from trimming fell into a wooden tub. The paving-block cutter used the wooden chipping tub as a working surface as he faced the blocks (Figure 19). Periodically, the tub was emptied of the waste chips.

Some of the objectives for paving blocks included a

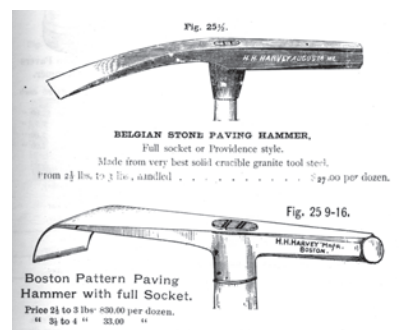




Figure 21 (above). Loading grout into a gondola car at the Woodbury Granite Co., Gray Quarry, Woodbury, Vermont.

Figure 22 (below). Woodbury Granite Co. advertisement for crushed granite.

**Crushed Granite.**

Vermont's roads should be among the best in the land.

**CRUSHED Woodbury Gray Granite**

screened to size, may be had from us in carlots at low cost.

For making Macadam roads, concrete walls or culverts this material is worth while.

secure foothold for horses, long wear, reduction of wheel noise, smooth ride, reduction of surface irregularity, and ease of cleaning. Paving block sizes decreased over time as experience showed that the smaller-sized blocks could better achieve these objectives.

By the 1920s, there were thirty-two different sizes! The following are a few of the more common paving blocks: Willard (18 by 14 by 12 inches), Russ (10 by 4 by 10 inches), Manhattan Special (5 by 4 by 8 inches), Rectangular (4 by 9 by 7 inches), and Belgian (5 by 5 by 6 inches).

Paving blocks were primarily used as street paving in large towns and cities. Most paving blocks were laid on a base of sand above gravel. A few were laid on concrete. Paving blocks were always laid with the smallest (hardway) surface exposed. This presented the hardest and best wearing face and, with the rift and lift surfaces on the sides, allowed easier trimming by the paver to provide tight-fitting joints between the blocks. A sand rammer was used to compress the sand. A paving hammer, with a grub hoe-like blade on one side and hammerhead on the other, was used to prepare the sand for seating the block and to pound the block into position after it was seated. There were three common styles of paving hammer—Belgian-pattern, Boston-pattern, and Washington, D.C.-pattern (Figure 20). Granite paving blocks have passed into oblivion, having been replaced by lower-cost asphalt paving.

## Crushing

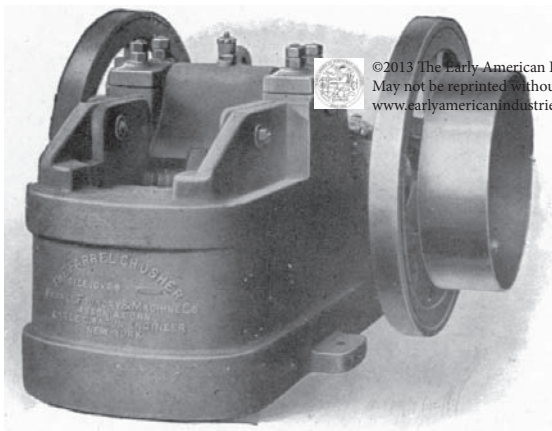
Small- to medium-size pieces of waste granite (grout) were processed into crushed granite (Figure 21). Crushed granite was primarily used for street and road construction, railroad ballast, and as an additive for artificial stone (Figure 22). Crushing granite requires about 33,000 pounds per square inch of compressive force. A rock crusher with crusher jaws measuring 13 by 24 inches was advertised to have a capacity of two hundred tons per day for 1½-inch stone and three hundred tons per day for 2½-inch stone and requiring thirty horsepower (Figures 23 and 24). Normally, a platform was positioned next to the crusher that received grout from a traveling derrick or cableway and would hold a day's supply. Screen sections were used to sort crushed rock ranging from 2½ inches to fine sand, which was then stored in storage bins according to size. For efficiency, a railroad spur often ran under the bin spouts since a single road contract could amount to a hundred or more car loads. A typical road foundation consisted of, from bottom to top, 5-inch, 3-inch, and 1-inch thick layers of crushed granite of decreasing size that was rolled with a fifteen-ton roller while being water saturated.

## Tool and Machinery Technology

Most of the world's great cultures have used stone for buildings, monuments, and municipal structures. The pyramids, sphinxes, and obelisks of Egypt, the temples of Greece, the aqueducts and roads of Rome, Brunelleschi's dome in renaissance Florence, and the amazing tight-jointed stone walls of Machu Picchu are all well-known examples. All of these cultures developed stone-working techniques and tools. Many machines of the granite industry were developed in the mid 1800s for the granite-producing industry around Aberdeen, Scotland. These included the overhead traveling crane, cableway, stone-cutting lathe, and sandblast machine, all of which were later introduced into and improved by the American granite industry.

It is usually difficult to attribute an invention with accuracy to an individual or country since inventing is an incremental process depending on the work of many earlier inventors. However, there are hundreds of United States patents relating to stone working and handling, and it is safe to say that Americans, at least during the nineteenth- and twentieth-centuries were major innovators in granite-working tools and machinery. U.S. innovations include: wedge and shims (Tarbox, ca. 1803), boom derrick and stone jack (Willard, ca. 1820s), bush

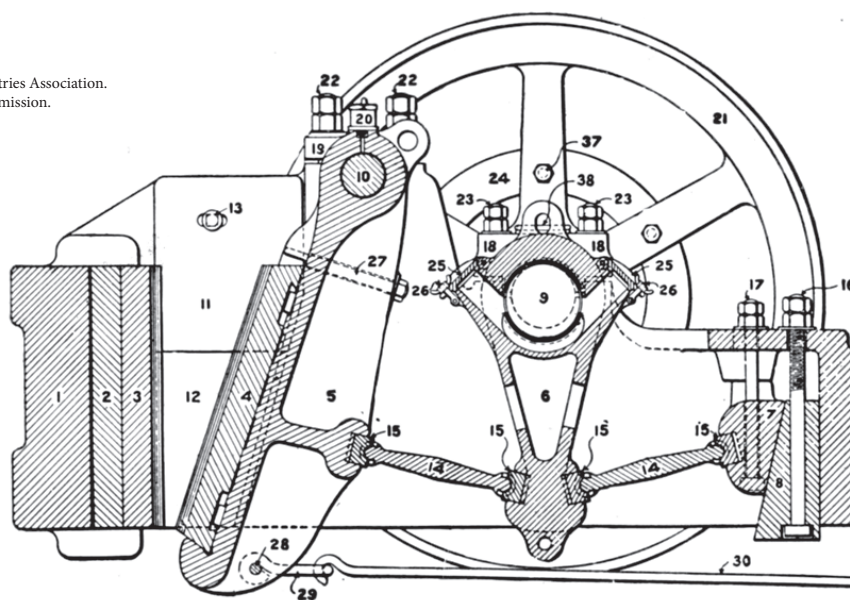




©2013 The Early American Industries Association.  
May not be reprinted without permission.  
www.earlyamericanindustries.org

Figure 23 (above). Rock crusher manufactured by Farrel Foundry & Machine Co., Ansonia, Connecticut.

Figure 24 (right). Engineering cross-section diagram of the rock crusher. Tremendous force is achieved by the toggles (14) pushing against the swinging plate (4).



hammer (Richards, 1828), steam quarry drill (Couch, 1849; Fowle, 1851), gang saw feed (Merriman, 1859), channeling machine (Wardwell, 1867), steam quarry pump (Hall, 1872), polishing machine (Wright, 1878), mechanical-surfacing machine (McDonald, 1879), geared locomotive (Shay, 1881), gang-saw abrasive feed (Ripley, 1883; Shortsleeve, 1885), pneumatic hammer (Dallett, ca. 1883; MacCoy, 1885), silicon-carbide abrasive (Acheson, 1891), pneumatic-surfacing machine (MacCoy, 1895), well railroad car (ca. 1890s), hollow quarry-drill bit (Leyner, 1898), disc-sharpening machine, (Lane, ca. early 1900s), dust-removal system (Ruemelin, 1926), and contour wire saw (Dessureau, 1958). Unfortunately, in the last few decades, the United States has lost its technology lead to countries such as France, Italy, Germany, Finland, and Japan, which are now manufacturing efficient quarrying equipment and complex multi-function, computer-controlled, granite-working machines (see Figure 41).

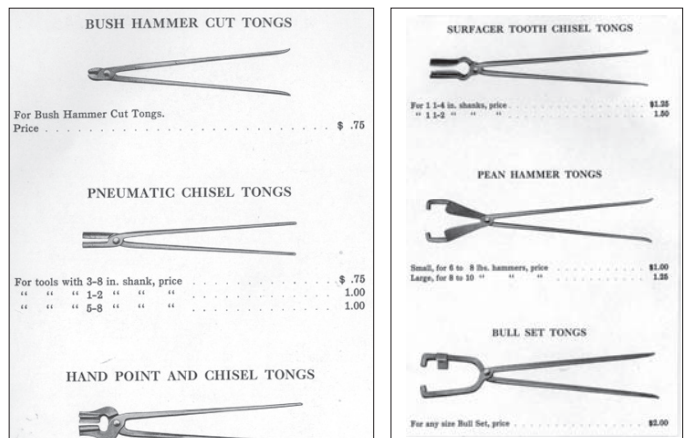
Blacksmiths repaired, sharpened, and tempered granite tools. They also designed and fabricated simple tools—the more complex tools and machines were made in the machine shop. Some stonecutters would sharpen their own tools, sending them to the blacksmith only when they needed to be tempered. Although many of the tools for carving limestone, marble, and granite are similar in general shape, the harder granite requires thicker and heavier versions. Before the advent of carbide-tipped tools, the blacksmith had to temper tools differently for each type of stone. For granite, the hardest of the three, the tool would be heated until overall white. In early days, the stonecutter's contract mandated one blacksmith for every ten to fifteen stonecutters. The introduction of Carborundum grinders and saws reduced the need for blacksmiths, and the introduction of carbide-tipped tools

in the late 1940s and early 1950s virtually eliminated that need. At first, the more expensive carbide-tipped tools were given only to journeyman cutters. Currently, a carbide-tipped tool costs about double the same tool in plain steel; however, the carbide-tipped tool stays sharp as much as ten times longer.

The granite-shed blacksmith used many of the standard blacksmith tools including the forge, anvil, leg vice, post drill, power hacksaw, forging hammer, ball peen hammer, straight peen hammer, cross-peen hammer, bevel-faced sharpener's hammer, slant-peen sharpening hammer, skew round-faced sharpening hammer, as well as a number of specialized tools for handling and sharpening granite tools. There were specialized tongs such as bush-hammer cut tongs, pneumatic-chisel bit tongs, hand point and chisel tongs, surfacer tooth-chisel tongs, bull-set tongs, and granite-wedge tongs (Figures 25 and 26). The granite-shed blacksmith also used specialized anvil-sharpening stakes such as

Figure 25 (below, left). Blacksmith's tongs for bush hammer cuts, pneumatic chisel bits, hand points, and hand chisels.

Figure 26 (below, right). Blacksmith's tongs for surfacer tooth chisels, peen hammers, and bull sets.



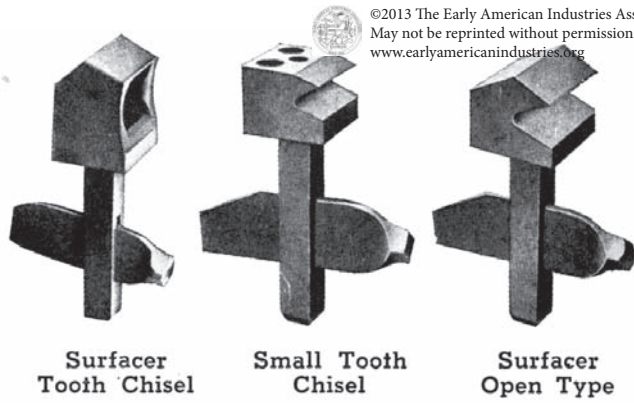
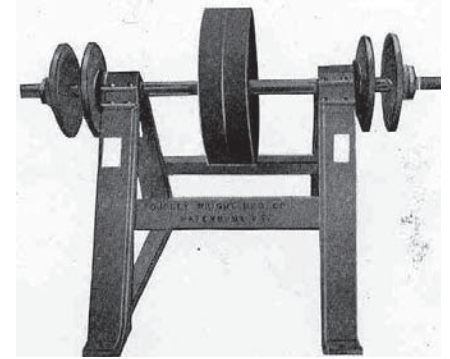


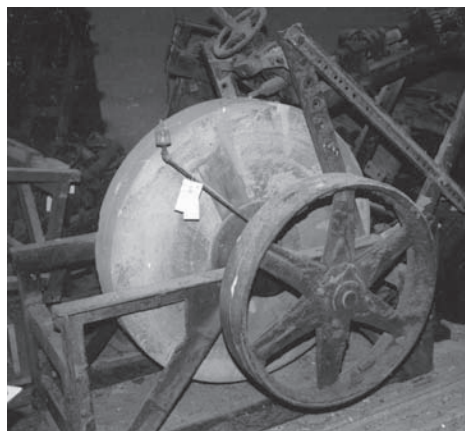
Figure 27 (left). Blacksmith's stakes for surfacing machine toothed chisels.  
 Figure 28 (right). Grindstone frame manufactured by Cooley Wright Mfg. Co., Waterbury, Vermont. A five-foot diameter, tool-sharpening grinding wheel was clamped between the hub pairs on each side of the frame. The drive pulley is in the center.



the surfacer four-point, tooth-chisel stake (Figure 27). The blacksmith shop also housed a tempering forge and quench tub for stone lathe-cutting discs. The forge was larger than normal to handle cutting discs which could measure up to eighteen-inches in diameter. The discs needed to be tempered after being sharpened in the Pirie sharpening machine described below.

Each tool-grinding machine consisted of two, 5-foot diameter grinding wheels and was used for sharpening hand chisels and surfacing-machine bush chisel cuts (Figure 28). A continuous stream of water was applied during sharpening. The grinders were powered by an electric motor via overhead shafting and flat belts. Two sizes of pulley were provided for two grinding speeds. High speed was used for sharpening bush-hammer cuts. The grinding wheels were normally located in a shed alcove or a small shed attached to the large shed so as to be conveniently near the stonecutters. There was a constant movement of tools between the stonecutters and sharpeners, carried by tool boys. After the advent of carbide-tip tools circa 1950, grinding wheels composed of a material specifically designed to grind carbide (for example, National's "Natalon") were used to grind worn carbide tips. Carbide tips were ground but not quenched like a steel-tipped tool. Grinding was intended to bring the carbide tip back to its original shape—with edges not too sharp or pointed and corners slightly beveled to prevent carbide breakage. Today, worn carbide tips are replaced and not sharpened.

The Pirie disc-sharpening machine, designed by Willis A. Lane of Barre, Vermont, sharpened the cutting discs for the stone-cutting lathes and, at an earlier time, the cutting



discs for the McDonald mechanical surfacer (see Figure 2). It had a large 8-inch wide, 4½-foot diameter grindstone that moved back and forth on its axle as it turned (Figures 29 and 30). This ensured even wear on the grindstone. After sharpening on the grinder, the discs were sent to the blacksmith shop for tempering.

Most medium- to large-size granite companies had a machine shop with several trained machinists (Figure 31). This shop would normally be furnished with several metal-working lathes of different sizes, drill presses, grinders, workbenches, welding equipment, a steel-top welding bench, and storage for metal stock and spare parts (Figure 32). None of this equipment was specific to the granite industry. The shop could repair just about any machine in the shed. The head machinist often designed custom machinery or modified existing machinery to meet special needs. Hence, the equipment inventory of a typical large shed included both standard manufactured machinery and many custom-designed and built machines.

### Evolution of Power Sources

Since granite is a tough and heavy material, the availability of power for quarrying, finishing, and transport was critical. The basic problem was the conversion of energy from various sources (draft animals, falling water, and burning wood or coal) into motive power and then transmitting that power to the granite-working and

**THE PIRIE**  
**Tool Sharpening Machine**

Is working well wherever tried. No Granite Manufacturer employing over fifty men can afford to be without one. One machine saves \$1,800 per year.

— For full particulars address —  
**PIRIE TOOL SHARPENING MACHINE CO., MONTPELIER, VT**

Figure 29 (above). Ad for the Pirie lathe disc sharpening machine (*Granite Cutters' Journal*, 1906)

Figure 30 (left). Pirie lathe disc sharpening machine manufactured by the Pirie Tool Sharpening Machine Co., Montpelier, Vermont.





Figure 31 (above). Machinist at the drill press in the Jones Brothers Co. machine shop.

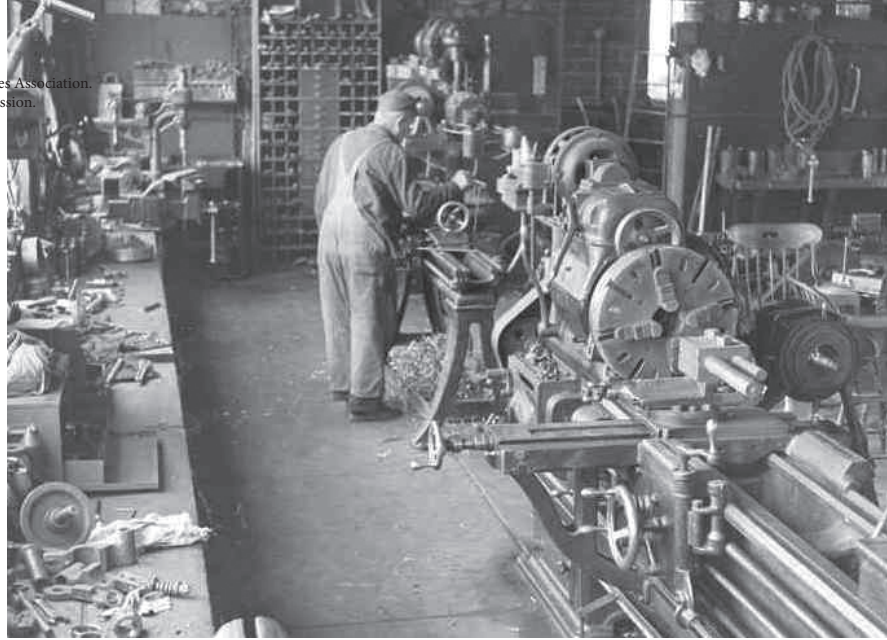


Figure 32 (right). Jones Brothers Co. machine shop with a large metal-working lathe in the foreground.

moving machinery. The cost of power was typically only a small part of the total cost of a granite operation, but it was a critical part. Any power interruption could shut down the entire manufacturing process. Granite became a major nationwide industry only after the introduction of highly efficient tools and machines and the availability of reliable power to run them. In the end, the choice of a power source depended on the scale of the granite operation, the number and size of local water power sites, the local availability and cost of fuel, and the possibility of sharing power sources with other local industries.

The evolution of power sources to run the granite-working tools and machinery was typical of an industry that depended on the latest technologies to remain competitive. At first, granite workers did most of the work by hand—drilling, splitting, lifting, surfacing, polishing, lettering, carving, and sculpting. Granite was quarried with hand tools such as the hand drill, drilling hammer, and wedge and shims. Granite was finished with hand tools such as the hand hammer and chisel. Granite was lifted and moved by such means as lever, hand-operated derrick, sledge and rollers. Granite quarrying and finishing was a slow and costly process and only relatively small granite pieces could be lifted and moved. Except for costal quarries where boat transport was available, granite markets were limited to areas close to the quarry, and the granite products were relatively simple—mostly stones for house foundations, hearths, steps, and window sills and lintels.



Figure 33. Ox cart and team at a Woodbury, Vermont, granite quarry. Before the railroad, carts were used to haul out waste granite.

Granite workers had some help from draft animals for heavy lifting with block and tackle and with sweep-operated derrick hoists, and for transport by sled or wagon. Quarry overburden and waste granite was removed by ox shovel and ox cart (Figure 33). Lifting of quarry blocks was done by horse sweep-powered derrick hoists and transport was accomplished by ox or horse-drawn wagon or, during winter, by sled—sometimes aided by block and tackle for very steep or muddy roads (see back cover). A horse could provide a continuous one-half horsepower, whereas a man could produce only about one-eighth continuous horsepower. The upkeep of a horse was about the same cost as the salary of a skilled worker.

The granite industry followed the factory system pioneered by the textile industry in the early 1800s in Waltham and Lowell, Massachusetts. This included the use of water and steam power, the integration of all manufacturing steps in one building, production by complex machinery, and distribution of power to machines located throughout the building via millworks. Prior to the use of steam engines, granite-finishing sheds were located at waterpower sites (at a rapids or waterfall) on streams and rivers for which the granite company had purchased the water rights or mill privilege. A millrace (or headrace) was used to channel water from a dam to a waterwheel (overshot, breast or undershot), which was connected via a millwork to the various granite-working machines such as gang saws, polishing machines, and



©2013 The Early American Industries Association.  
May not be reprinted without permission.  
www.earlyamericanindustries.org



*Figure 34. Water turbine. The flange with gate valve on the left connects to the penstock. The vertical shaft transmits power up to the main floor of the mill.*

lathes. A waterwheel had the virtue of simplicity; it had only a single moving part, could be made almost entirely of wood, and could be constructed by traditional craftsmen such as millwrights, carpenters, and blacksmiths. No precision parts, enclosure or flywheel were needed. Waterwheels rotate slowly—the larger the wheel, the slower the rotation. Wheels mostly range in diameter from eight to thirty feet with rotation speeds of twenty to five rpm, respectively. As a result, one of the tasks of the millworks was to increase the rotational speed (by belts, pulleys, and gears) to that needed by the powered machines.

Later, circa 1850s, waterwheels were increasingly replaced by water turbines, which ran at higher speed and produced more power (Figure 34). In addition, turbines were compact, durable, efficient, and low cost. Whereas waterwheels were made primarily of wood, turbines, because of their design and fabrication complexity, were made of iron and were manufactured at distantly located factories. The turbine operated with water under pressure conveyed from a dam via a wooden or iron penstock. Since turbines were oriented horizontally with vertical shafts, gearing was needed to transfer power from the turbine shaft to the horizontal main shaft of the millworks (Figure 35).

Although water power was relatively inexpensive, it had two major drawbacks. First, sheds had to be located next to a waterpower site where there might not be an available workforce or worker housing and where the shed might be exposed to potential flood damage. Second, during periods of low rainfall, there might not be

enough water to operate the shed. For these reasons, waterwheels and water turbines were gradually replaced by stationary steam engines and later by steam turbines. Usually, the same system of shafts, pulleys and belts that had been used for water power was retained. Steam also made possible the development of portable

tools and machines powered via a flexible steam hose, such as steam quarry drills. Initially, wood-burning steam boilers were used, supplied with fuel from local woodlots. As coal became available and as local wood became scarce and more expensive (ca. 1880s), boilers were converted to burn coal (Figure 36). For large installations, a coal trestle might be constructed for efficient railroad delivery. An important by-product of the boiler was the use of steam to heat the sheds during winter operation. Steam was a more costly type of power, but the drawbacks of water power were avoided. The steam engine could be located almost anywhere, could be designed with a range of output capacities, and was not dependent on stream flow.

Compared to the waterwheel, the steam engine cost more to purchase, had to be shipped at added cost from a remote manufacturer, had to be continuously attended and maintained, and was more costly to repair. These negatives, added to the fact that small steam engines were not as efficient in fuel use, meant that steam engines were mostly installed by large granite firms. Economy of scale drove the granite industry to build boiler houses with multiple large steam boilers, to build compressor rooms with multiple large air compressors, and finally to purchase electric power from public utilities. This both reduced the cost of power and improved reliability by the backup power generation capability of multiple prime movers. Often an entrepreneur would install a large air compressor and sell compressed air to surrounding small to medium-sized granite sheds that couldn't afford to buy a compressor. Or, an entrepreneur might build a granite shed with compressed air, electricity, heat, and lighting and rent space to small granite firms. Sometimes, a small firm purchased excess compressed air or electric power from a large neighboring firm.



*Figure 35. Dam at the Hardwick Granite Co. polishing mill, Hardwick, Vermont. A turbine in the basement powered gate-type and vertical polishing machines on the main floor.*



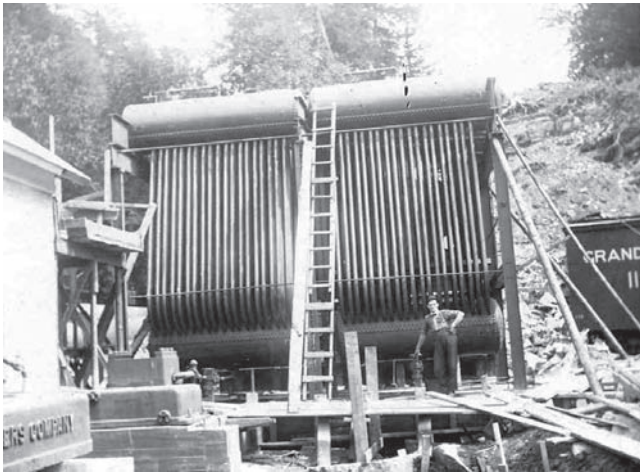


Figure 36. One thousand horsepower Babcock & Wilcox tubular steam boiler.

Quarries posed special problems with respect to power. Quarries were often located at higher elevations with no rivers or streams for water power. By the 1870s and 1880s, coal was often transported to the quarry by wagon to fire boilers, which provided steam for drills and derrick hoists. Later, if the quarry was serviced by a railroad, coal might be brought in more economically. Sometimes water was so scarce that it was a challenge even to find enough to replace the water lost by the steam engine's escaped steam and to provide water for wet drilling.

Just as waterwheels were replaced by water turbines, reciprocating-piston steam engines were replaced by steam turbines in applications where greater power and rotational speed were needed, such as for driving air compressors and electric generators. Turbines were best used for applications requiring high rotational speed and continuous operation. Compared to the steam engine, the steam turbine was simpler, having only one moving part. In addition, the steam turbine had smaller size and lower weight per horse power and higher efficiency (for large sizes), and could run for months unattended.

Movable boilers and steam engines (with a self-contained fuel supply) allowed the development of the primary means of granite transport—rod locomotives, saddle-tank locomotives, geared locomotives, and locomotive cranes. The steam locomotive made possible the low-cost transport of granite via rail and opened up the interior granite quarries for exploitation. Initially, locomotives were wood fired, but by the 1880s, they were being rapidly converted to coal. Compared to seasoned hardwood of the same heating value, coal weighed half or less and had a volume several times less. Although by

the 1870s interior New England was well serviced by rail, it was not until quarry railroads with their steep grades and sharp curves were built in the 1880s and 1890s to haul granite from the quarries to the finishing sheds that the interior New England granite companies really began to prosper. Strong-traction, saddle-tank locomotives were often used on quarry railroads and, for extreme grades, geared locomotives, on which all the wheels were driven, were used to provide outstanding tractive power for grades of 10 percent and more.

As mentioned above, steam was initially used to power quarry drills and derrick hoists. Steam was difficult to handle and always dangerous. After circa 1880s, compressed air gradually replaced steam (Figure 37). Pneumatic rock drilling was pioneered in the U.S. in 1866 with the building of the Hoosac Tunnel in western Massachusetts where the drills were powered by air compressors directly connected to water turbines. Compressed air had many advantages. There was an inexhaustible supply of air, air exhaust was no problem in confined areas, and pipe leaks were not as dangerous. Also compressed air could be transmitted several miles without significant loss, and it could be easily subdivided for use by many tools and machines. Finally, compressed air could be used expansively in unmodified steam engines or in a variety of specialized air motors. The one major drawback was the inefficiency of a compressed air system (only 40–55 percent in the 1890s) due to heat loss during compression. However, the convenience of compressed air more than made up for this inefficiency. Air compressors required relatively high torque and rotational speed, which could be delivered by steam turbines. Electric motors did an even better job of driving air compressors. The use of compressed-air, deep-hole quarry drills, plug drills, jackhammers, and derrick hoists as well as surfacing machines and pneumatic hammers in the sheds did not really become widespread until the advent of the electric motor-driven air compressor in the 1890s (Figure 38).

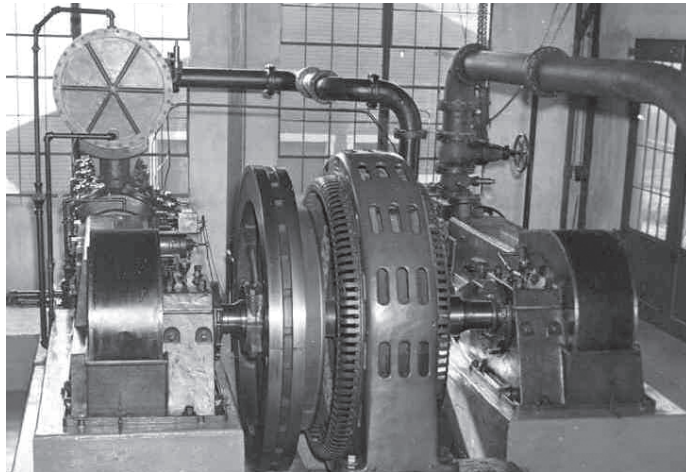
The next major step in power technology was the introduction of electrical power in the late-nineteenth century and early-twentieth century. The introduction of electricity had the most profound effect of any new power source on the organization and operation of the granite quarry and granite shed. Initially, granite sheds generated their own electric power by water- or steam-turbine-powered electric generators (Figures 39 and 40). Later, in the early-twentieth century, public electric power utilities increasingly supplied power to the sheds. In addition to making possible the efficient production of compressed air, the electric motor was used to power



©2013 The Early American Industries Association.  
May not be reprinted without permission.  
www.earlyamericanindustries.org

*Figure 37 (left). A maze of compressed air hoses at a Barre, Vermont, granite quarry with a pneumatic quarry drill in the background.*

*Figure 38 (below). Electric motor-driven air compressor. The motor is in the center with the two compressor stages on either side.*



virtually all the non-pneumatic granite working tools and machinery. At first, a single, large, electric motor would be used to replace the steam engine or turbine, using existing millworks. As smaller, lower-cost motors became available, multiple motors were used, each powering a group of similar co-located granite-working machines. Finally,

each machine was manufactured with its own integral electric motor. The use of one motor per machine greatly simplified power transmission from motor to machine (usually a geared or direct connection) and meant that the motor needed to be running only when the machine was in use. Also, a machine with an integral motor could be more easily moved. The mechanical millworks, which consumed from 20 to 50 percent of the power generated were thus replaced by electrical conductors that consumed 5 percent or less of the power generated. As electric motors continued to decrease in size, the power per motor volume and weight increased and hand-held tools were developed with integral motors powered via an electric cord. An important by-product of the electric generation was the ability to use electric lighting for late winter afternoons and cloudy days.

Steam and compressed air is more difficult to transport over long distances due to frictional and heat losses and therefore led to the use of localized boiler houses and compressor rooms. Transport of power mechanically, for example by hemp or manila rope, steel cable, or rods, is even more limited, typically only a fraction of a mile. Electrical power can be transmitted over long distances (at high voltages) without significant energy loss, which made region-wide electric utilities possible and allowed the tapping of previously unexploited remote hydro power. Later in the twentieth century, the

*Figure 39 (below). Woodbury Granite Company's combined hydro- and steam-powered electric plant at Hardwick, Vermont. Note the iron penstock and surge tank at the left. The steam plant with its large iron smokestack is behind the hydropower plant. The conveyor belt and blower duct on the right transports waste wood and sawdust from a sawmill (when available) to be burned in the steam boilers.*

*Figure 40 (right). A wintertime view of Woodbury Granite Company's power plant. The ice geysers are the result of a leaky penstock and northern Vermont's frigid winters.*







©2013 The Early American Industries Association.  
May not be reprinted without permission.  
www.earlyamericanindustries.org

*Figure 41 (left, top). Diesel-powered Ingersoll Rand air compressor with pneumatic quarry drill in the background at Swenson Granite Company's Fletcher Quarry in Woodbury, Vermont. The quarry drill comes from Finland and the carbide-tipped drill bits from Japan.*



*Figure 42 (left). Caterpillar diesel forklift truck at the Fletcher Quarry. It cost \$1,300,000 new and each tire costs \$8,000 to replace.*

internal combustion engine began to power both electric generators and air compressors, especially at remote quarry locations where electric service might not be readily available (Figure 41). In modern quarries, diesel engines power large forklift trucks and long-haul flatbed trucks (Figure 42). The Fletcher Quarry in Woodbury, Vermont's highest producing quarry, consumes forty thousand gallons of diesel fuel per year.

### Immigrant Granite Workers

During the mid- and late-1800s and early-1900s, granite workers from Scotland, Italy, Ireland, England, Spain, Sweden, Finland, Norway, and other countries were attracted by America's booming marble and granite industries. Later, French Canadians came in large numbers, many as strike breakers, a role that some have still not forgiven. Immigrant granite workers filled jobs at all levels, including quarry and shed owners, architects, artists, sculptors, stonecutters, quarrymen, machine operators, engineers, mechanics, and draftsmen. Many Scots came from Aberdeen, an important granite center, and many of these immigrants purchased and operated granite quarries in America. Immigrants from Spain and Sweden often came from the granite centers at Saragossa and Goteburg, respectively. The Italians came mostly from the marble region of Carrara in Tuscany and the granite region of Viggiu in Lombardy. Many were highly trained and had apprenticed for as many as ten years, starting as young boys. As Vermont's granite industry boomed, Italian marble carvers moved from Rutland to Vermont's granite centers to try their hands (and as it turned out, successfully) at granite carving. (See following pages for a description of the jobs in the finishing shed.)

The training of Italian carvers often included formal art school, for example *Accademia di Belle Arti di Carrara* or *Accademia di Belle Arti di Brera* (Milan), as well as practical work in a stone shed. The apprentice went from watching to applying what he saw to taking responsibility and performing for critics, the master carvers. In the early stages of his apprenticeship in the stone shed, he might clean up the shop, pick up chips, put away tools, deliver tools to the blacksmith, pick up stone from nearby shops, run a variety of errands, sharpen tools, take pay to the carvers, build scaffolding, polish stone, and pull rope for the master's bow drill. When an apprentice was ready after a few years of training, he would start to work on stone, typically in the following sequence as his skill grew: break down a stone with a hand hammer and point; draw and carve letters; put a straight face on a stone with chisels and bush hammer; put a cornice or molding on a stone; carve leaves and other simple ornaments; carve flowers, foliage, and capitals; rough out a relief, bas-relief, or full-round statue; and then watch the master finish the carving. As a point of comparison, consider the apprenticeship standards developed in Barre in 1946. The term of apprenticeship for stonecutters was three years and for polishers and sawyers two years. Sharpeners worked on tools for six cutters during the first six months, eight cutters during the second six months, ten cutters for the third six months, and fourteen cutters for the last six months.

Since many immigrants were itinerant workers, following the work wherever it was available, wives and children often stayed home and husbands sent money back home. Wages in the American granite industry were much better than in Europe. Some waited until they were established and then sent for their family. In the meantime, they usually lived in boarding houses provided by the granite companies or in private boarding houses (Figure 43). Many returned home to retire and, tragically, often to die from silicosis. With the warmer climate of southern Europe, many immigrant granite workers were used to working in open-sided sheds which allowed the granite dust to dissipate to the outdoors. Also, there were fewer dust-producing machines in use and the granite itself was softer, resulting in less dust. The European marble workers who came to work in the granite industry were completely unfamiliar with silicosis since marble dust does not cause silicosis. European stone workers called silicosis the "American disease"!



## Jobs in the Finishing Shed

This list of jobs includes those of workers who specified, finished or moved granite in the finishing shed and their supervisors. There was also a large group of workers who provided services in support of the first group including, salesman (4), estimator (1), cost clerk (1), bookkeeper (1), secretary (3), timekeeper (1), master mechanic/machinist (6), boiler room engineer (1), maintenance man (1), engineer (1), carpenter (2), blacksmith (2), tool sharpener (3), disc sharpening machine operator (1), and blacksmith's helper (or tool boy). Other workers such as architects, artists and teamsters typically did not work for a granite company but rather contracted their services. The number of workers for each job category (given in parentheses) is based on the Jones Brothers Co. cutting plant in Barre, Vermont, in the 1930s. These numbers can be considered typical of a large, cutting-plant operation. There was variation in the number of employed granite workers depending on the amount of work under contract, the availability of workers, and the movement of workers between granite companies. For example, at Jones Brothers the number of stonecutters varied from ten to twenty.

At Jones Brothers, the stone setter led a setting crew to erect mausoleums and vaults. A Jones Brothers crew usually consisted of men borrowed from various areas around the shed. The Woodbury Granite Co., during its

busy years, had up to eight full-time setting crews. (See figures this page and opposite). The machinists, engineers, and carpenters were organized into a maintenance department under the direction of a maintenance supervisor. Depending on the amount of work, some granite workers did multiple jobs, for example: washing and boxing, sculpting and carving, stencil cutting and blowing, expediting and car loading, estimating and cost clerking, and engineering and maintenance.

*Plant Manager* was in charge of all operations—manufacturing, sales, and accounting (1).

*Plant Superintendent* was in charge of overall plant manufacturing operations including production quotas (1).

*Supervisor* was in charge of one part of plant operations (4, one per finishing shed and one for the maintenance crew)

*Foreman* was in charge of a group of men and assigned work, graded and marked stone, and acted as union representative (A senior employee from each work area acted as foreman – for example, stonecutters, surfacers, polishers, grinders, machinists.)

*Draftsman* designed and drew full-size details for lettering and shape carving (6).

*Sculptor/Model Maker* sculpted in clay, often from an artist's design, and produced a plaster model from the clay sculpture (3 sculptors/carvers).

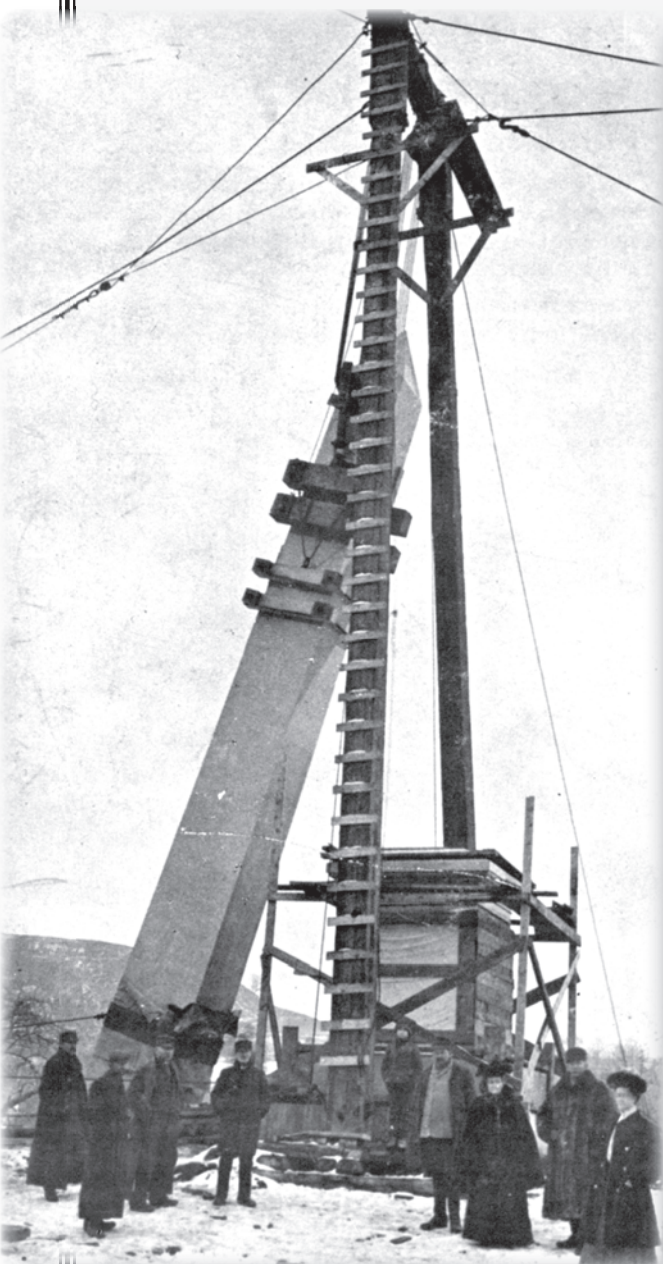
*Carver* sculpted full round figures and bas-relief in granite, often working from a sculptor's model (3 sculptors/carvers).

*Shape Carver* carved flowers, leaves, vines, etc., often working from a draftsman's full-size detail (3 sculptors/carvers).

*Letter Carver* carved raised and sunk letters, often working from a draftsman's full-size detail (By this time, most lettering was performed by sand blasters.)

*Etcher* used carbide or diamond-tipped etching tool to ornament a polished surface, a relatively new technology at this time and apparently not yet adopted at Jones Brothers.

*Stencil Cutter (or Rubber Cutter)* cut letters and shapes according to a draftsman's full-size detail (10 stencil cutters/sand blasters).







*Sand Blaster (or Blower)* sandblasted letters and shapes using a rubber template (10 stencil cutters/sand blasters).  
*Grader (or Measurer)* marked a slab for initial splitting. (This was typically the foreman's job.)  
*Breaker* swung the striking hammer while another, typically the quarry foreman, held the slab splitter. This divided the slabs into monument size pieces (1).  
*Surfacing Machine Operator* operated a pneumatic surfacing machine (4, one per surfacing machine).  
*Sawyer* operated a gang or circular saw (4, one per gang saw).  
*Stonecutter* rough shaped and finished stone by hand (10 to 20).  
*Lathe Operator* turned press rolls, chocolate rolls, columns, balusters, urns, vases, and spheres (3, two cutting lathes and one polishing lathe).  
*Boring Pit Operator* aligned and drilled press and chocolate roll arbor holes (1).  
*Corrugating Machine Operator* operated machines that cut corrugations in chocolate rolls and beds (2, for the roll corrugating machine, the bed corrugating machine, and the corrugation mating machine.)  
*Grinder Operator* operated a top or edge grinder with a Carborundum wheel or a wheel with contained abrasive bricks (4, one per horizontal, vertical, disc, and molding grinder).  
*Polisher* operated a gate-type or vertical polishing machine (4, one per polishing machine).  
*Bed Setter* set stones in a bed of plaster for the polishing machines (1).  
*Crane Operator* operated an overhead crane from the trolley or operator's cab following hand signals from the lumper (5, one per crane).  
*Derrick Operator (or Derrick Engineer)* operated a yard boom derrick from the derrick hoist house following hand signals from the lumper (1).  
*Lumper* was responsible for moving stone from workstation to workstation and attaching the crane or derrick hook to a cable or chain hitch (5, one per derrick or crane).  
*Paving-Stone Cutter* split and shaped paving stones. (By this time, the paving block cutter had passed into oblivion.)  
*Stone Cleaner* cleaned the finished stone with an acid wash. (3 washers/boxers).  
*Stone Boxer* crated cleaned stone for shipping. (3 washers/boxers).  
*Loader* was responsible for the loading of flatbed trucks and railroad flatcars and making sure the load was secured and well balanced. (1 loader/expediter).  
*Expediter* checked each stone against a shipping list to insure that all the stones for an order or contract had been loaded and would be shipped. (1 loader/expediter).  
*Stone Setter* directed a crew that erected buildings, large monuments and mausoleums beyond the capability of retail

organizations or contractors. (1).  
*Grunt* picked up grout and, in general, cleaned up. This was the lowest level job in shed. (1).

*Opposite page: An erecting crew at work raising the shaft of the Joseph Smith Monument into its final position in 1905, Sharon, Vermont. At this time, the Smith monument was the tallest polished granite obelisk in the world. The obelisk shaft is 38½ feet high and weighs thirty-nine tons.*

*At left: A Woodbury Granite Co. erecting crew laying up the granite blocks for the Memorial Building in Hardwick, Vermont.*





© 2013 The Early American Industries Association.  
May not be reprinted without permission.  
www.earlyamericanindustries.org

Figure 43. A quarry boardinghouse with the Woodbury Granite Company's Gray Quarry in the background. An existing farmhouse was renovated and expanded. The farm's barn is visible to the right of the house.

## Silicosis, Tuberculosis and Granite Dust

"I've lived through most of Barre's labor troubles. . . . Men wanted the elimination of dust. That was always a sore spot. I don't blame them. I know what I'm talking about. My father, brother and three uncles all died from stonemason's TB."<sup>1</sup> Those are the words of a granite worker describing the effects of silicosis in *Men Against Granite*. Silicosis was caused by the prolonged—seven to eight years— inhalation of excessive levels of airborne granite dust produced primarily by pneumatic, granite-working tools and machinery that were in use as early as 1887.

"Modern machinery came in and silicosis slaughtered family after family—through ruthlessness of big industry," noted the Mayor in *Men Against Granite*. "The safety devices now are far from perfect. . . . And they come too late to save the men who worked in the shed before. That dust is already in their lungs. Even if they leave the sheds, as many of them do, the damage is done. It will get them. Some go fast and others linger on for years."<sup>2</sup>

As Messrs. Tobin and White noted in their application for a 1924 patent for a "Dust Remover for Stone Dressing Machinery," "This dust is injurious to the health and it has been found that in the granite districts of Vermont and elsewhere, the life of a stone-working mechanic is relatively short. If a mechanic works on surfacing stones for too long a time, the dust will effect his lungs and eventually cause his death by tuberculosis"<sup>3</sup>

Silicosis-induced tuberculosis was the cause of the premature death of large numbers of granite workers and the devastation of their families—most dying in their 50s, 40s, and even 30s. Stonemason's TB or the "white death" had been known to stonemasons themselves by the late 1800s and was known to exist in foundry, mining, and other stone processing industries long before that. By 1908, convincing statistical and

epidemiological evidence of the severity of the disease in granite workers had been published.

"The present problem—In 1915 there were 2,050 granite cutters working [in Barre], while in 1919 only 1,240. An analysis of the death certificates for the past twenty years indicated that 86 percent of the cutters died from tuberculosis," noted Dr. D.C. Jarvis, in 1923 in "The Upper Respiratory Tract in Granite Dust Inhalation."<sup>4</sup>

Granite workers were exposed to, and were willing to accept, a wide variety of risks that could be minimized but not completely eliminated, such as explosives, falling rocks, flying stone and metal chips, excessive noise, and exploding machinery. However, granite workers were less willing to accept airborne granite dust that they viewed as an unnecessary risk.

Increased competition in the industry put strong pressure on stone-shed owners to purchase more efficient stone-working machinery. Unfortunately, much of this machinery greatly increased the levels of dust—especially the surfacing machines. By around 1903, Barre's granite-cutters union was advocating the installation of dust-removal equipment and was including dust-control clauses in its labor agreements. Some examples of the clauses include: "Cutters must provide themselves with brooms, and no air power to be used to remove dust unless by special permission";<sup>5</sup> "Turning down of grindstones to be done outside working hours unless water is kept running on them in sufficient quantities to keep down the dust";<sup>6</sup> and "No surface cutting machines to be worked in the cutting shed during working hours."<sup>7</sup> Union president James Duncan wrote in a 1904 issue of the *Granite Cutters' Journal* "To those familiar with the modern granite cutting plants, it is easy to understand the high mortality among granite cutters because respiratory disease exists. These sheds are splendidly equipped with all the known appliances facilitating the output of granite, but they are generally lacking in one thing, mainly a means of ventilating dust which is produced in the course of granite cutting."<sup>8</sup>

Dust control was the single most important health issue for the granite industry. By the early 1900s, deaths due to silicosis and tuberculosis were so numerous that there actually developed a shortage of skilled granite workers. If the climate allowed, working outside or in open-walled sheds was an effective measure (Figures 44 and 45). However, during New England's cold winters, the sheds were kept closed—often resulting in dust so thick that a worker could not see a coworker at the next banker. Exhaust fans in shed walls and ventilating roof





cupolas were not very effective (Figure 46). Face masks with filters and helmets with an air supply were tried but found to either clog or to be too clumsy, hindering a man's work (Figures 47 and 48). Wet stone working was introduced in both the quarry and finishing shed and for certain operations like quarry drilling and tool sharpening on grindstones was quite effective.

Dr. D.C. Jarvis, a local Barre physician, was very vocal on the health problems of granite workers and did a great deal to focus the public's attention on the need to find solutions. Highly trained workers were being lost to early deaths. Sons were not entering the granite business, often at the urging of their granite worker fathers. There was declining immigration of skilled Europeans who, having heard of working conditions from relatives and friends in the U.S., did not want to risk silicosis. Although he had a great concern about the future of the industry, Dr. Jarvis, along with most other physicians at this time, did not seem to have a clear understanding of the connection between the dust and the disease. Dr. Jarvis's medical writings seem to imply

that manufacturers had a limited responsibility for the health of their employees, that workers had a personal responsibility to remain productive, and that the workers' personal sanitary habits away from the workplace were a cause of tuberculosis infection.

Prudential Life Insurance and Metropolitan Life, the two primary insurers of America's industrial workers, had been collecting morbidity and mortality data for many years. In the early 1900s, using statistical and epidemiological methods to analyze this data, Frederick L. Hoffman, a statistician at Prudential, along with his counterpart at Metropolitan, Louis Dublin, were the first in America to convincingly link the presence of granite dust in the workplace to the incidence of tuberculosis among granite workers. "The sanitary dangers of air contaminated by disease-breeding germs are probably not so serious as generally assumed ... [rather] the destructive effects of the dust-laden atmosphere of factories and workshops are a decidedly serious menace to health and life,"<sup>9</sup> This linkage was strongly suggested by the nationwide decline in the incidence of tuberculosis



Figure 44 (above, left). The workers of a granite shed posing for the photographer. The granite worker on the right is leaning on his pneumatic surfacing machine, which is being operated outside during the warm weather. The block being surfaced can be seen just in front of the surfacing machine operator.

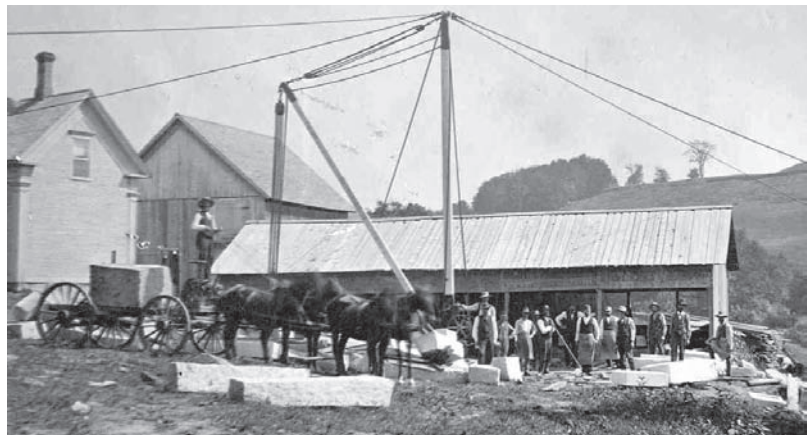


Figure 45 (above, right). A Hardwick, Vermont, granite shed in the summer with its sides open. Many of the workers appear to be working outdoors with their stones scattered across the yard.

Figure 46 (below). Granite shed with string of eight ventilating cupolas.



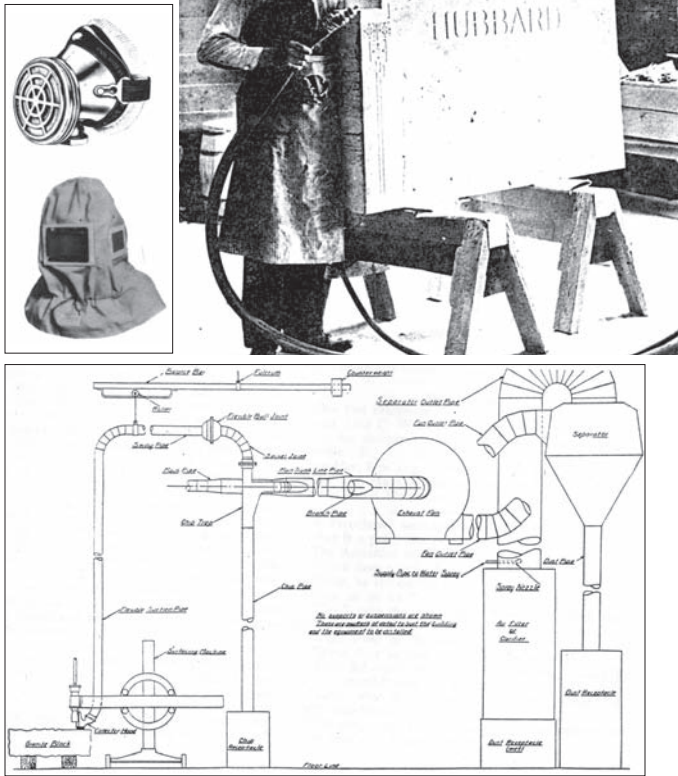


Figure 47 (top, left). Respirator with filter and protective hood for sandblast operator.

Figure 48 (top, right). Sandblast operator with air-supplied helmet, ca. 1925.

Figure 49 (bottom). A complete dust removal system adequate for the entire cutting shed (Engineering Diagram, Granite Cutter's Journal, 1924).

after 1900, except for workers in the dusty trades. By 1919, the death rate in Barre from tuberculosis was 23.3 per 10,000 whereas the rate for the rest of Vermont was only 9 per 10,000. In 1929, the U.S. Public Health Service published a definitive mortality study of Barre's granite workers, which showed that at sixty million particles of dust per cubic foot, "100 percent of the workers had at least early signs of silicosis within four years."<sup>10</sup> It also established a safe limit for dustiness at between nine to twenty million parts per cubic foot. The authors of this study commented "With a properly designed system of exhaust ventilation, it is possible to remove a large proportion of the dust, even without the use of an individual fan for each machine."<sup>11</sup> (Figure 49)

Tragically, although the necessary technology existed to solve the problem, it was not until another decade had passed (1939) that effective dust removal equipment was universally installed in Vermont. Why was it that universal installation of dust control equipment occurred only after 1939 even though the connection between dust inhalation and tuberculosis had been recognized, at least by some, as

early as 1900 and effective dust removal equipment had been installed in a few sheds in Concord, New Hampshire, and Barre as early as the late 1910s and early 1920s? Some probable reasons are: (1) the high cost of really effective dust removal equipment (the typical cost for a dust control system for an average size stone shed in the 1920s–30s was \$5,000, in some cases this was almost the cost of the shed itself); (2) an unwillingness to make this investment due to increased costs of doing business (salaries, taxes, complex machinery) and the increased competition from other granite areas (for example, Elberton, Georgia, and St. Cloud, Minnesota); (3) the mistaken assumption that existing dust control measures were effective; (4) the confusion caused by the medical profession pointing to causes for tuberculosis other than dust inhalation such as home hygiene; (5) the strong work ethic of granite workers who continued to work even though most of them knew that the work environment was killing them; and (6) the reduced union bargaining strength after the influx of strike-breaking French-Canadian workers resulted in an open shop ("American plan") workplace.

In 1922, Barre shed owners proposed a 20 percent wage cut and a health commission to begin a study for the removal of dust created by tools and machinery used in cutting granite. The workers rejected this offer and the owners declared the "American plan" to be in effect. Finally, on September 1, 1937, the Barre Granite Cutters Union and the shed owners agreed to a labor contract that mandated the universal installation of effective dust removal equipment. Stonecutters agreed to a reduction of salary demands of a dollar per day to help pay for the dust removal equipment. After two years of delay, the equipment was finally universally installed by 1939. At the same time, the Vermont Department of Public Health, Industrial Hygiene Division, instituted periodic inspections of the dust removal equipment to insure compliance with the dust control agreement. This included the regular testing of the dust removal equipment, with a vacuum gauge, to insure adequate suction.

Over time, a wide variety of dust control measures, many of limited effectiveness, were attempted. However, by far the most effective and universally applicable safety measure was the removal of granite dust at its source—the stonecutter's banker, sandblast room, or dust-producing machine—by suction through a system of ducts. This system had to be engineered for each installation, taking into account the building configuration and the type and location of each stone-working machine and stonecutter banker (Figure 50). The various





elements of a dust collection system included: a suction head (or nozzle) at the banker or attached to a machine's frame near the pneumatic tool (Figure 51); a flexible duct connecting to the suction head that allowed easy movement as the work location changed; a flexible duct support with friction rod, friction wheel, and counterweight; a chip trap to remove granite chips from the airflow so as to prevent damage to the fan, duct work and dust filter bags; a fan or blower; a rigid duct work system, running through the shed, increasing in size as more and more of machines and workstations were connected; and an external (located outside the shed) dust filter with an array of self-cleaning cloth bags. The bags required periodic replacement due to the highly abrasive nature of granite dust. The pile of trapped dust was shoveled out from the bottom of the filter.

Richard Ruemelin of the Ruemelin Manufacturing Co., Milwaukee, Wisconsin, was a key innovator in dust control equipment. Although there were earlier patents, Ruemelin was the first inventor and manufacturer to provide a full line of effective and reliable equipment including banker dust collectors, surfacer dust collectors, sand blast cabinets with curtains, and dust filters. This was the first time a complete dust removal system could be assembled from standard manufactured parts. Ruemelin was issued three important dust removal patents: a dust collector (filter) with multiple hanging cloth filter bags, which were periodically shaken by an electric motor to prevent the bags from clogging (1926); a dust removal device for a single stonemason banker, which was easily positioned to the work (1933); and an adjustable dust and chip collector for pneumatic surfacing machines (1934). Although almost all granite sheds are now equipped with effective dust removal equipment, it is still necessary to educate workers about the hazards of dust, to train them for proper use of the equipment, and to keep the equipment in good working order.

### Safety and Health

“Last week a stone had dropped [from the derrick chain] with the toppling crash of thunder, skidded across the floor and pinned the Spaniard Manuel against the wall with a crushed leg. Manuel’s scream pierced the



Figure 50 (above). A granite shed with an installed dust removal system. Nozzles, flexible ducts, chip traps, and rigid duct work are visible.



Figure 51 (right). Carver at his banker with suction nozzle.

echoing roar of the hurtling block.”<sup>12</sup> This story was one of many reported in *Men Against Granite* that illustrates the perils of working in the granite industry. “I used to handle the dynamite too,” one Scots-Irish derrickman remembered. “The worst one I ever saw was when they were blasting out under a ledge. The fuse was lit all right, but it took a long time to go off. They thought it had gone dead or something. I told them not to go back under there but this fellow did, this French fellow. It went off just as he was crawling under. Jesus help me, I never want to see anything like that again! Blew him out like a cannonball. Blew the hair right off his head, the clothes off his body. Blew his eyes out, his ears off, there were pieces of wood and stone blown right into his head and body.”<sup>13</sup>

These granite worker stories from *Men Against Granite* leave no doubt that the quarrying and finishing of granite was an inherently dangerous occupation. Injuries to eyes were caused by flying granite and steel chips. Injuries to the ears were caused by the high noise levels of the tools and machinery. The noise often continued in their heads when they were at home and some developed tinnitus—a permanent ringing in the ears.

“Just Another Guy Working” described how the noise affected him. “The noise is the worst thing. It makes me deaf. It’s a hell of a racket with the saws grinding back and forth. You know it takes an hour to



saw four inches into granite. The drills are going all the time, and them big cranes are smashing overhead. You get vibration from the air-pressure machines. Jack hammers sound like machine guns. At quitting when the noise stops your head feels funny inside, the ringing stays in your ears, but you get used to it.”<sup>14</sup>

Large, powerful, hand-held pneumatic hammers caused numb fingers. Bodily injuries were caused by a variety of events. A granite worker could be crushed between two stone blocks, between two railroad cars, or under a falling block or grout box. He could be struck by a sliding block, a flying stone from a premature or delayed quarry explosion, flying metal from an exploding steam boiler or machinery, or a falling derrick caused by an oversize load. He could be entangled in a moving rope or injured by falling from a quarry ledge, a quarry ladder, a grout box, a derrick mast, or while riding on a lifted block. He could be wound around machinery shafting or caught in machinery gearing or belts. He could be scalded by steam escaping from a steam drill or from a burst steam boiler. Hands were crushed in pulley blocks and limbs severed by flying cables or chains. In the six years after 1914, when Vermont’s Compensation Law went into effect, there were fifteen fatalities at Barre granite quarries and stone sheds that were reported to the Commissioner of Industries.

When a worker could not work due to injury, it typically inflicted severe financial hardship on his family. The company might continue his salary for a short time, but if the disability was of long duration, the salary stopped. Any financial help was voluntary on the part of the company. In some cases, this help was forced by legal action. In 1913, the Woodbury Granite Co. was sued by the brother of Fred Angelo, who was killed by a blast in the Woodbury Granite Co. No. 9 quarry in Woodbury. He had just arrived from Italy and left a wife and four children in Italy. The company settled for \$2,500.

Gradually, due to union pressure and government regulation, safety rules and regulations were instituted such as, never ride the derrick hook or a lifted stone, never stand under a suspended stone, immediately take cover when a blast whistle sounds, avoid loose clothing around machinery, and use only sparkless implements when handling explosives. The wearing of safety equipment was mandated, for example: safety glasses or goggles when using tools or operating machines

that produce flying stone or metal chips, steel-tip shoes, hard hat, ear protectors (muffs) and ear plugs near noisy machinery, safety belt, safety harness, and safety line (Figure 52). The safety line was attached to the safety harness and had a snap hook at the end. The quarry worker was required to snap the hook onto the ride box when being lifted out of the pit, and a rigger



Figure 52. Stonecutter’s goggles (Granite Cutters’ Journal, 1910).

had to snap his safety line onto a derrick rope, mast ladder rung, or rope eye wherever he was working on the derrick. Today, all quarrymen must wear hard hats, long pants, and steel-toed shoes. Some quarry drill operators wear double ear protection—both ear plugs and ear muff protectors.

## Labor Unions

The granite industry was one of the earliest and most completely unionized of any industry in America. The Granite Cutters Union and its associated publication, the *Granite Cutters Journal*, was established in 1877 by granite workers in the Maine granite communities of Hurricane Island, Clark Island, Dix Island, and Vinalhaven. The South Ryegate (Vermont) Branch of the Granite Cutters National Union was organized on April 2, 1885. When management of the local granite companies heard of the impending organization of a union, they petitioned the State’s Attorney to dispatch deputies. The deputies arrived in South Ryegate armed with revolvers and handcuffs only to find the granite workers totally peaceful. The workers were arrested and taken away to be jailed but were immediately bailed out with money raised among the town’s citizens. An indictment was brought against the workers but was quickly dismissed by the court for all except for three of them. After a long series of legal maneuvers, the three were fined a nominal twenty dollars each. This incident established that the union was, in fact, a legal institution in Vermont.

Reasons for early unionization of the granite industry are not hard to find. The granite industry was (and is) highly competitive with tight margins and required large capital investment in tools and machinery, which strongly motivated management to keep the payroll down. Work was highly variable, especially in the building granite industry, where a large contract was often completed before the next contract had yet been signed, leading management to hire and fire large groups of workers at one time. Safety rules were often viewed by management as reducing efficiency and production. Finally, many im-





migrants from Europe had a strong socialist tradition and tended to view management with suspicion, perceiving worker exploitation (Figure 53). The Granite Cutters International Association (successor to the Granite Cutters National Union) was the earliest and most effective of the granite unions. Unions were also organized for other workers such as quarrymen, sharpeners, lumpers, derrickmen, and boxers. As a counterbalance to the increasing strength of unions, granite manufacturer's associations were organized by company owners in most of the major granite communities. For example, by 1909, there were thirty-one manufacturer association members in Hardwick and Woodbury, Vermont.

The main concerns of the granite unions were regular paydays, hourly rates, and hours worked per week. In the late 1800s, granite workers were paid at irregular and unpredictable intervals, were earning on average only 30 to 35 cents per hour, and were working six ten-hour days per week. The other big union issue was its concerns about airborne granite dust. Workers strike demands included regular paydays, an eight-hour workday, increased hourly wages, and safety conditions on the use of pneumatic tools. Granite workers at this time did not have medical insurance, workman's compensation, or retirement plans, although granite workers could buy voluntary insurance for \$1.00 per week with the employer contributing \$1.50 per week. They also had to endure the ups and downs of the granite business. Added to this were the strikes; for example, there were more than a dozen strikes in Hardwick and Woodbury from 1896 to 1933. The granite worker could expect to have a lot of unpaid "vacation time"!

As an example of a labor agreement, in 1911, a five-year settlement on a new scale of wages was agreed upon in all branches of the granite industry in Hardwick. Lumpers and drillers were to get an increase from \$2.08 to \$2.25, from \$2.23 to \$2.35, and from \$2.35 to \$2.40. Those earning \$2.50 or more would have no change. Stonecutters were to get an increase from \$3.10 to \$3.25 for monumental granite and from \$3.20 to \$3.30 for building granite. Weekly pay

and the Saturday half holiday (that is, the men worked only half a day on Saturday) were included in the agreement. The half holiday would be in force during the summer months or when there was light during the working hours. During the winter months, the men would labor seven and one-half hours in the day in lieu of the half holiday. The bumper was excluded in the new contract. Blacksmiths and sharpeners were to receive the same increase as the cutters and the polishers would also receive an increase in pay.

From the perspective of the employer, labor strikes significantly increased his labor costs, impacted his ability to deliver on schedule, and caused cash flow problems in meeting fixed costs. The result of these strikes was an ever-increasing wage scale—from 25¢ to 30¢ per hour and a ten-hour workday in 1890 to \$1.00 per hour and an eight-hour workday in 1920.



Figure 53. Socialist Block (Socialist Labor Party), Barre, Vermont. Built in 1899, mostly by Italian stonecutters, the Socialist Block was a political and social focal point for Barre's granite workers and for many years included a union co-operative store.

The building granite business declined during the 1920s and finally collapsed in the early 1930s due partly to worker strikes and the onset of the Great Depression but due mostly to the increasing availability of alternative lower-cost building materials such as concrete, glass, steel panels, and stone veneers

and the unwillingness of governments and companies to spend extra for granite ashlar-clad buildings. The American monumental granite business is still active but is under increasing pressure from international competition, especially from China and India.

### Author

EAIA member Paul Wood is a retired electrical engineer, who worked his entire career in the computer industry. He is interested in the tools, implements and machinery of the granite industry and of nineteenth- and early-twentieth-century farming in New England.

### Notes

1. Mari Tomasi and Roaldus Richmond, "A Modern Guild," *Men Against Granite*. Works Progress Administration, Federal Writers Project, 1936-40 (Also available at <http://memory.loc.gov/ammem/wpaintro/vtcat.html> or in Tomasi, Mari, et al., *Men Against Granite* (New



- England Press, 2004).
2. "The Mayor," *Men Against Granite*
  3. Edward M. Tobin and Emmet M. White, "Dust Remover For Stone-Dressing Machinery," U.S. Patent Office, no. 1,504,994, August 12, 1924.
  4. D.C. Jarvis, M.D. "The Upper Respiratory Tract in Granite Dust Inhalation," *The Annals of Otology, Rhinology and Laryngology*, vol. XXXII, (1923).
  5. Granite Cutters' International Association, 1903 contract with Barre manufacturers.
  6. Ibid.
  7. Ibid.
  8. James Duncan, *Granite Cutters' Journal* (1904).
  9. Frederick L. Hoffman, "Mortality from Consumption in Dusty Trades," *U.S. Bureau of Labor Bulletin* no. 79, (1908): 633-875.
  10. Albert E. Russell et al., "The Health of Workers In the Dusty Trades," *U.S. Public Health Service Bulletin* no. 187 (1929).
  11. Ibid.
  12. "Up On The Hill," *Men Against Granite*.
  13. "Scots-Irish Derrickman," *Men Against Granite*.
  14. "Just Another Guy Working," *Men Against Granite*.

## Additional References

### Books and Journal Articles

- Bale, M. Powis. *Stone-Working Machinery*. London: Crosby Lockwood and Co., 1884.
- Barre Granite Association. *Apprenticeship Standards for the Granite Industry*. Barre, Vermont: Barre Granite Association 1946.
- Barre Museum of the Aldrich Public Library. *Carlo Abate—A Life in Stone* (pamphlet). Barre, Vermont: ca. 1986.
- Bielenberg, Kristina, et al. *Granite Artists and Their Work* (exhibition catalog). Barre, Vermont: Barre Ethnic Heritage Studies Project and First Branch Gallery, 1978.
- Bigelow, Jacob. *History of the Mount Auburn Cemetery*. Boston: James Munroe and Co., 1860.
- Bowles, Oliver. *Stone Cutting and Polishing*. U.S. Department of Interior, 1958.
- "Credit Ratings, 1917-18." Boston: National Association of the Granite Industries of the United States, 1918.
- Dale, T. Nelson. *The Granites of Maine*. U.S. Geological Survey, 1907.
- Dale, T. Nelson. *The Commercial Granites of New England*. U.S. Geological Survey, 1923.
- Fenwick, Carrol, ed. *Barre In Retrospect*. Barre, Vermont: Friends of the Aldrich Public Library, 1975.
- Forbes, Harriette M. *Gravestones of Early New England and the Men Who Made Them 1653-1800*. Boston: Houghton Mifflin, 1927.
- Gove, Bill. *Sky Route To The Quarries Quarry*. Williamstown, Vermont: View Publishing, 2004.
- Grindle, Roger. *Tombstones and Paving Blocks, the History of the Maine Granite Industry*. Rockland, Maine: Courier of Maine Book, 1977.
- Hatch, Theodore. "Control Of The Silicosis Hazard In The Hard Rock Industries," *The Granite Cutters Journal*, June 1930 .
- Hoffman, Frederick L. "Mortality from Consumption in Dusty Trades," *U.S. Bureau of Labor, Bulletin* no. 79, (1908): 633-875.
- Jones, Robert C. et al. *Vermont's Granite Railroads*. Boulder, Col.: Pruett Publishing Co., 1985.
- Munroe, Charles E. and Clarence Hall. *A Primer on Explosives for Metal Miners and Quarrymen*. U.S. Government Printing Office, 1915.
- Peele, Robert. *Compressed Air Plant*. New York: John Wiley & Sons, 1920.
- Preserving a Palace of Art* (brochure). Harrisburg: Pennsylvania Capitol Preservation Committee, 2000.
- Pinkstone, William G. *The Abrasive Ages*. Lititz, Pennsylvania: Sutter House, 1974.
- Richardson, Wendy. "'The Curse of Our Trade': Occupational Disease in a Vermont Granite Town." *Vermont History*, 60, no. 1 (Winter 1992).
- Russell, Albert E. et al. "The Health of Workers In the Dusty Trades: Exposure to Siliceous Dust (Granite Industry)," *U.S. Public Health Service Bulletin*, no. 187 (1929).
- Sass, Jon A. *The Versatile Millstone—Workhorse of Many Industries*. Newton, N.C.: Society for the Preservation of Old Mills, 1984.
- Seager, D. R. "Barre Vermont Granite Workers & The Struggle Against Silicosis, 1890-1960." *Labor History*, 42, no. 1 (2001): 61-79.
- Sessions, Gene. *Celebrating A Century of Granite Art*. Montpelier, Vermont: T.W. Wood Art Gallery, 1989.
- Smith, Robert. *The Granite City*. Edinburgh: John Donald Publishers, 1989.
- State of Wisconsin. *Wisconsin State Capitol Guide and History* (brochure). Madison: Division of Buildings and Police Services, 2000 .
- Stebbins, F.H. "Dust Collecting Systems Adapted for Use In Connection with the Granite Industry." *The Granite Cutter's Journal*, September 1924.
- Tomasi, Mari. *Like Lesser Gods*. Milwaukee, Wisc.: Bruce Publishing Co., 1949.
- Tymeso, Mildred McClary. *The Norton Story*. Worcester, Mass.: Norton Co., 1953.





©2013 The Early American Industries Association.  
May not be reprinted without permission.  
[www.earlyamericanindustries.org](http://www.earlyamericanindustries.org)

